

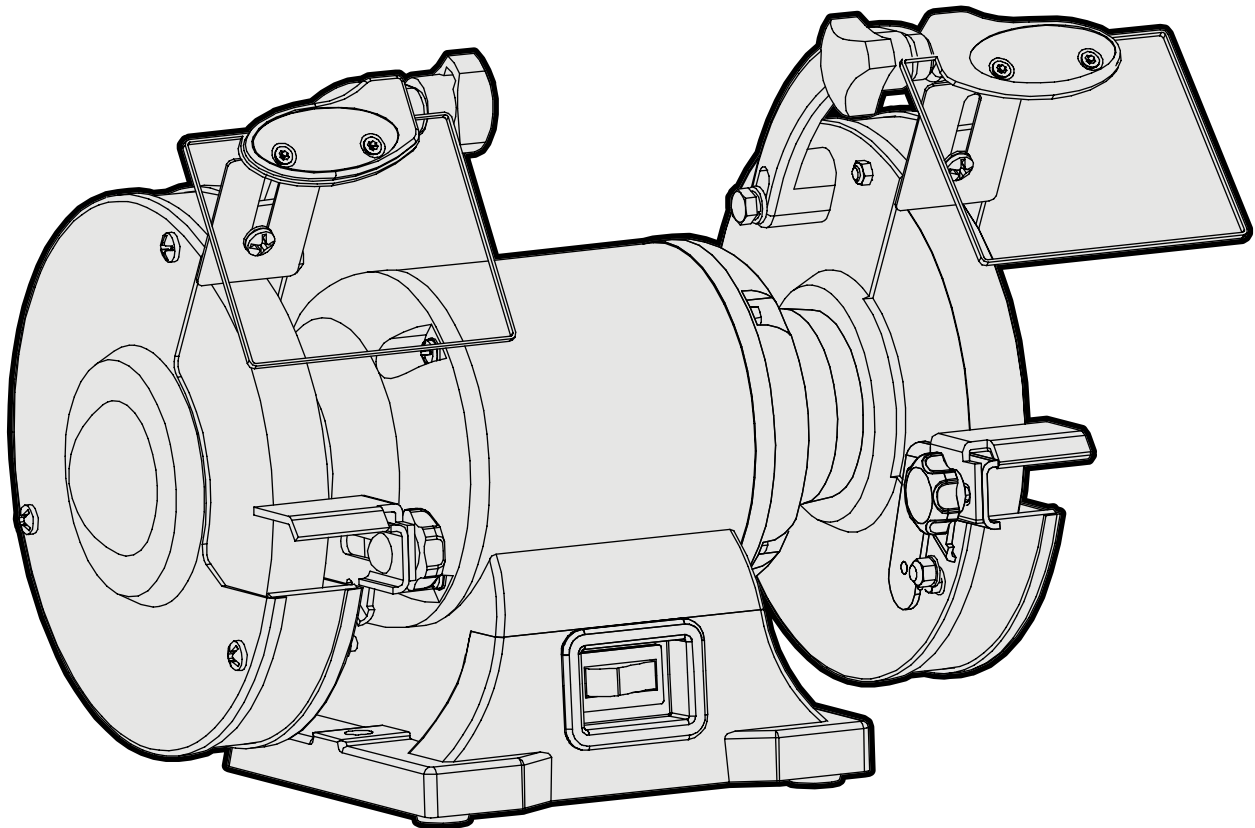

MODEL BG4266

6-INCH BENCH GRINDER

Instruction Manual



NEED HELP? CONTACT US!

Have product questions? Need technical support? Please feel free to contact us:



1-800-232-1195 (M-F 8AM-5PM CST)



TECHSUPPORT@WENPRODUCTS.COM

IMPORTANT: Your new tool has been engineered and manufactured to WEN's highest standards for dependability, ease of operation, and operator safety. When properly cared for, this product will supply you years of rugged, trouble-free performance. Pay close attention to the rules for safe operation, warnings, and cautions. If you use your tool properly and for its intended purpose, you will enjoy years of safe, reliable service.

For replacement parts and the most up-to-date instruction manuals, visit **WENPRODUCTS.COM**

CONTENTS

WELCOME	3
Introduction	3
Specifications.....	3
SAFETY	4
General Safety Rules	4
Specific Rules for Your Bench Grinder.....	6
Electrical Information.....	7
BEFORE OPERATING	8
Unpacking & Transportation	8
Know Your Bench Grinder.....	9
Assembly & Adjustments.....	10
OPERATION & MAINTENANCE	11
Operation	11
Troubleshooting Guide.....	12
Maintenance.....	13
Exploded View & Parts List.....	15
Warranty Statement	17

To purchase accessories for your tool, visit **WENPRODUCTS.COM**

Cast Iron Bench Grinder Stand (Model No. 4288)

INTRODUCTION

Thanks for purchasing the WEN Bench Grinder. We know you are excited to put your tool to work, but first, please take a moment to read through the manual. Safe operation of this tool requires that you read and understand this operator's manual and all the labels affixed to the tool. This manual provides information regarding potential safety concerns, as well as helpful assembly and operating instructions for your tool.

 **SAFETY ALERT SYMBOL:** Indicates danger, warning, or caution. The safety symbols and the explanations with them deserve your careful attention and understanding. Always follow the safety precautions to reduce the risk of fire, electric shock or personal injury. However, please note that these instructions and warnings are not substitutes for proper accident prevention measures.

NOTE: The following safety information is not meant to cover all possible conditions and situations that may occur. WEN reserves the right to change this product and specifications at any time without prior notice.

At WEN, we are continuously improving our products. If you find that your tool does not exactly match this manual, please visit wenproducts.com for the most up-to-date manual or contact our customer service at **1-800-232-1195**.

Keep this manual available to all users during the entire life of the tool and review it frequently to maximize safety for both yourself and others.

SPECIFICATIONS

Model Number	BG4266
Motor	120V, 60 Hz, 2.1A
Wheel Speed	3450 RPM
Wheel Size	6 inches x 3/4 inch
Arbor Size	1/2 inch
Wheel Grit	36 Grit (coarse), 60 Grit (medium)
Weight	14 pounds
Product Dimensions	12 x 7-1/2 x 8 inches

GENERAL SAFETY RULES

 **WARNING!** Read all safety warnings and all instructions. Failure to follow the warnings and instructions may result in electric shock, fire and/or serious injury.

Safety is a combination of common sense, staying alert and knowing how your item works. The term “power tool” in the warnings refers to your mains-operated (corded) power tool or battery-operated (cordless) power tool.

SAVE THESE SAFETY INSTRUCTIONS.

WORK AREA SAFETY

1. **Keep work area clean and well lit.** Cluttered or dark areas invite accidents.
2. **Do not operate power tools in explosive atmospheres, such as in the presence of flammable liquids, gases or dust.** Power tools create sparks which may ignite the dust or fumes.
3. **Keep children and bystanders away while operating a power tool.** Distractions can cause you to lose control.

ELECTRICAL SAFETY

1. **Power tool plugs must match the outlet. Never modify the plug in any way. Do not use any adapter plugs with earthed (grounded) power tools.** Unmodified plugs and matching outlets will reduce risk of electric shock.
2. **Avoid body contact with earthed or grounded surfaces such as pipes, radiators, ranges and refrigerators.** There is an increased risk of electric shock if your body is earthed or grounded.
3. **Do not expose power tools to rain or wet conditions.** Water entering a power tool will increase the risk of electric shock.
4. **Do not abuse the cord. Never use the cord for carrying, pulling or unplugging the power tool. Keep cord away from heat, oil, sharp edges or moving parts.** Damaged or entangled cords increase the risk of electric shock.
5. **When operating a power tool outdoors, use an extension cord suitable for outdoor use.** Use of a cord suitable for outdoor use reduces the risk of electric shock.

6. **If operating a power tool in a damp location is unavoidable, use a ground fault circuit interrupter (GFCI) protected supply.** Use of a GFCI reduces the risk of electric shock.

PERSONAL SAFETY

1. **Stay alert, watch what you are doing and use common sense when operating a power tool. Do not use a power tool while you are tired or under the influence of drugs, alcohol or medication.** A moment of inattention while operating power tools may result in serious personal injury.
2. **Use personal protective equipment. Always wear eye protection.** Protective equipment such as a respiratory mask, non-skid safety shoes and hearing protection used for appropriate conditions will reduce the risk of personal injury.
3. **Prevent unintentional starting. Ensure the switch is in the off-position before connecting to power source and/or battery pack, picking up or carrying the tool.** Carrying power tools with your finger on the switch or energizing power tools that have the switch on invites accidents.
4. **Remove any adjusting key or wrench before turning the power tool on.** A wrench or a key left attached to a rotating part of the power tool may result in personal injury.
5. **Do not overreach. Keep proper footing and balance at all times.** This enables better control of the power tool in unexpected situations.
6. **Dress properly. Do not wear loose clothing or jewelry. Keep your hair and clothing away from moving parts.** Loose clothes, jewelry or long hair can be caught in moving parts.

GENERAL SAFETY RULES

 **WARNING!** Read all safety warnings and all instructions. Failure to follow the warnings and instructions may result in electric shock, fire and/or serious injury.

Safety is a combination of common sense, staying alert and knowing how your item works. The term “power tool” in the warnings refers to your mains-operated (corded) power tool or battery-operated (cordless) power tool.

SAVE THESE SAFETY INSTRUCTIONS.

7. If devices are provided for the connection of dust extraction and collection facilities, ensure these are connected and properly used. Use of dust collection can reduce dust-related hazards.

POWER TOOL USE AND CARE

1. **Do not force the power tool. Use the correct power tool for your application.** The correct power tool will do the job better and safer at the rate for which it was designed.

2. **Do not use the power tool if the switch does not turn it on and off.** Any power tool that cannot be controlled with the switch is dangerous and must be repaired.

3. **Disconnect the plug from the power source and/or the battery pack from the power tool before making any adjustments, changing accessories, or storing power tools.** Such preventive safety measures reduce the risk of starting the power tool accidentally.

4. **Store idle power tools out of the reach of children and do not allow persons unfamiliar with the power tool or these instructions to operate the power tool.** Power tools are dangerous in the hands of untrained users.

5. **Maintain power tools. Check for misalignment or binding of moving parts, breakage of parts and any other condition that may affect the power tool's operation. If damaged, have the power tool repaired before use.** Many accidents are caused by poorly maintained power tools.

6. **Keep cutting tools sharp and clean.** Properly maintained cutting tools with sharp cutting edges are less likely to bind and are easier to control.

7. **Use the power tool, accessories and tool bits, etc. in accordance with these instructions, taking into account the working conditions and the work to be performed.** Use of the power tool for operations different from those intended could result in a hazardous situation.

8. **Use clamps to secure your workpiece to a stable surface.** Holding a workpiece by hand or using your body to support it may lead to loss of control.

9. **KEEP GUARDS IN PLACE** and in working order.

SERVICE

1. **Have your power tool serviced by a qualified repair person using only identical replacement parts.** This will ensure that the safety of the power tool is maintained.

CALIFORNIA PROPOSITION 65 WARNING

Some dust created by power sanding, sawing, grinding, drilling, and other construction activities may contain chemicals, including lead, known to the State of California to cause cancer, birth defects, or other reproductive harm. Wash hands after handling. Some examples of these chemicals are:

- Lead from lead-based paints.
- Crystalline silica from bricks, cement, and other masonry products.
- Arsenic and chromium from chemically treated lumber.

Your risk from these exposures varies depending on how often you do this type of work. To reduce your exposure to these chemicals, work in a well-ventilated area with approved safety equipment such as dust masks specially designed to filter out microscopic particles.

SPECIFIC RULES FOR YOUR BENCH GRINDER

 **WARNING!** Do not operate the power tool until you have read and understood the following instructions and the warning labels.

BENCH GRINDER SAFETY

1. This bench grinder is designed for sharpening and honing cutting tools, using the appropriate accessories. Using the machine for any other purpose for which it is not designed may result in serious injuries, machine damage and voiding of the warranty.

2. Grinding wheel safety:

- Only use grinding wheels rated for a speed higher than 3450 RPM (maximum RPM of the tool).
- Inspect wheels for cracks or fragments before starting the machine. Replace damaged wheels immediately. Never use a questionable grinding wheel, as the RPM of the machine can send broken wheel fragments flying at high speeds.
- Do not use a wheel that vibrates. If a wheel vibrates, it may be that the bearings of the shaft need replacing.
- Check that the grinding stone can rotate smoothly before starting the machine.
- The grinding wheel is for grinding. Never attempt to cut anything with the grinding wheel.

3. The use of accessories or attachments not recommended by the manufacturer may result in a risk of personal injury.

4. **DANGER:** fire hazard. Do not grind or polish magnesium or magnesium alloys.

5. Preventing accidental starting. Make sure the power switch is in the OFF position prior to plugging in the machine. Always make sure the power switch is in the OFF position and the machine is unplugged when doing any cleaning, adjustments, assembly, setup operations, or when not in use.

PERSONAL SAFETY

1. Operate in a well ventilated area. Keep the floor area around the bench grinder level and free of slippery substances or other tripping hazards.

2. Wear ANSI-approved safety goggles to protect your eyes from sparks and chips. Use hearing protection to

protect yourself from hearing loss.

3. **DO NOT** wear loose clothing or jewelry as they might get drawn in by the tool. Tie back long hair.

4. People with pacemakers should consult their physician(s) before use. Electromagnetic fields in close proximity to pacemakers could cause pacemaker interference or pacemaker failure.

5. Chips are harmful to your health. Use NIOSH-approved dust masks or other respiratory protection during operation and cleaning.

6. Always turn off and unplug the bench grinder before making any adjustments or repair tasks. Never adjust the bench grinder or the workpiece while the tool is running.

PREPARING THE BENCH GRINDER

When transporting the bench grinder, carry it by the base. Never carry the device by its guards or its accessories.

1. Examine the bench grinder for any damaged or missing parts. Replace or repair damaged parts before operation. Periodically check that all nuts, bolts and other fasteners are properly tightened.

2. Do not operate this tool until it is completely assembled and installed according to the instructions. Make sure all adjustments are correct and all connections are tight. Keep all guards in place.

DURING OPERATION

1. Never start the machine with any load already applied to either grinding wheel. Stand to the side of the bench grinder during start-up. Switch it ON and let the bench grinder reach full speed for roughly one minute to warm up the wheel and to ensure proper operation.

2. Never grind on a cold wheel. Run the bench grinder for one full minute before applying the workpiece. Cold wheels have an increased likelihood of chipping during operation.

SPECIFIC RULES FOR YOUR BENCH GRINDER

⚠ WARNING! Do not operate the power tool until you have read and understood the following instructions and the warning labels.

3. Only grind on the face of the grinding wheel. Do not grind on the side of the wheel.
4. Keep clear of moving parts. Keep arms, hands and other vital appendages away from the grinding and honing wheel. Do not reach behind or beneath the rotating wheel. Avoid awkward operation and hand positions. An accident could easily send the operator's hand into the wheel.
5. If you are interrupted when operating the bench grinder, complete the process and switch the bench grinder off before looking up.
6. Always hold the workpiece firmly against the tool rest.
7. Never attempt to cut anything with the grinding wheel.
8. Do not use the bench grinder unless all guards are in place. Do not operate with any guard disabled, damaged, or removed. Moving guards must move freely and close instantly.
9. Disconnect the power source and allow the wheels to come to a complete stop before making any adjustments to either the machine or the grinding wheels.
10. Clean the machine thoroughly when changing material types in workpieces. Combining certain materials can increase the chances of an explosion or fire hazard.
11. Should any component of your bench grinder be missing/damaged or fail in any way, shut off the switch and remove the plug from power supply outlet. Have a certified technician replace the missing, damaged, or failed parts using only identical replacement parts before resuming operation.

ELECTRICAL INFORMATION

GROUNDING INSTRUCTIONS

In the event of a malfunction or breakdown, grounding provides the path of least resistance for an electric current and reduces the risk of electric shock. This tool is equipped with an electric cord that has an equipment grounding conductor and a grounding plug. The plug **MUST** be plugged into a matching outlet that is properly installed and grounded in accordance with ALL local codes and ordinances.

1. **Do not modify the plug provided.** If it will not fit the outlet, have the proper outlet installed by a licensed electrician.
2. **Improper connection** of the equipment grounding conductor can result in electric shock. The conductor with the green insulation (with or without yellow stripes) is the equipment grounding conductor. If repair or replacement of the electric cord or plug is necessary, **DO NOT** connect the equipment grounding conductor to a live terminal.
3. **Check** with a licensed electrician or service personnel if you do not completely understand the grounding instructions or whether the tool is properly grounded.
4. **Use only three-wire extension cords** that have three-pronged plugs and outlets that accept the tool's plug (Fig. 1). Repair or replace a damaged or worn cord immediately.

CAUTION! In all cases, make certain the outlet in question is properly grounded. If you are not sure, have a licensed electrician check the outlet.

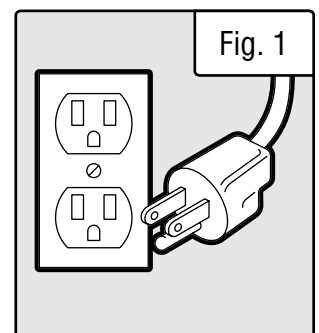

ELECTRICAL INFORMATION

GUIDELINES AND RECOMMENDATIONS FOR EXTENSION CORDS

When using an extension cord, be sure to use one heavy enough to carry the current your product will draw. An undersized cord will cause a drop in line voltage resulting in loss of power and overheating. The table below shows the correct size to be used according to cord length and ampere rating. When in doubt, use a heavier cord. The smaller the gauge number, the heavier the cord.

AMPERAGE	REQUIRED GAUGE FOR EXTENSION CORDS			
	25 ft.	50 ft.	100 ft.	150 ft.
2.1A	18 gauge	16 gauge	16 gauge	14 gauge

- 1. Examine extension cord before use.** Make sure your extension cord is properly wired and in good condition. Always replace a damaged extension cord or have it repaired by a qualified person before using it.
- 2. Do not abuse extension cord.** Do not pull on cord to disconnect from receptacle; always disconnect by pulling on plug. Disconnect the extension cord from the receptacle before disconnecting the product from the extension cord. Protect your extension cords from sharp objects, excessive heat and damp/wet areas.
- 3. Use a separate electrical circuit for your tool.** This circuit must not be less than a 12-gauge wire and should be protected with a 15A time-delayed fuse. Before connecting the motor to the power line, make sure the switch is in the OFF position and the electric current is rated the same as the current stamped on the motor nameplate. Running at a lower voltage will damage the motor.

UNPACKING & TRANSPORTATION

⚠ WARNING! Do not plug in or turn on the tool until it is fully assembled according to the instructions. Failure to follow the safety instructions may result in serious personal injury.

UNPACKING

With the help of a friend or trustworthy foe, carefully remove the bench grinder from the packaging. Make sure to take out all contents and accessories. Do not discard the packaging until everything is removed. Check the packing list below to make sure you have all of the parts and accessories. If any part is missing or broken, please contact our customer service at **1-800-232-1195** (M-F 8-5 CST), or email techsupport@wenproducts.com.

PACKING LIST

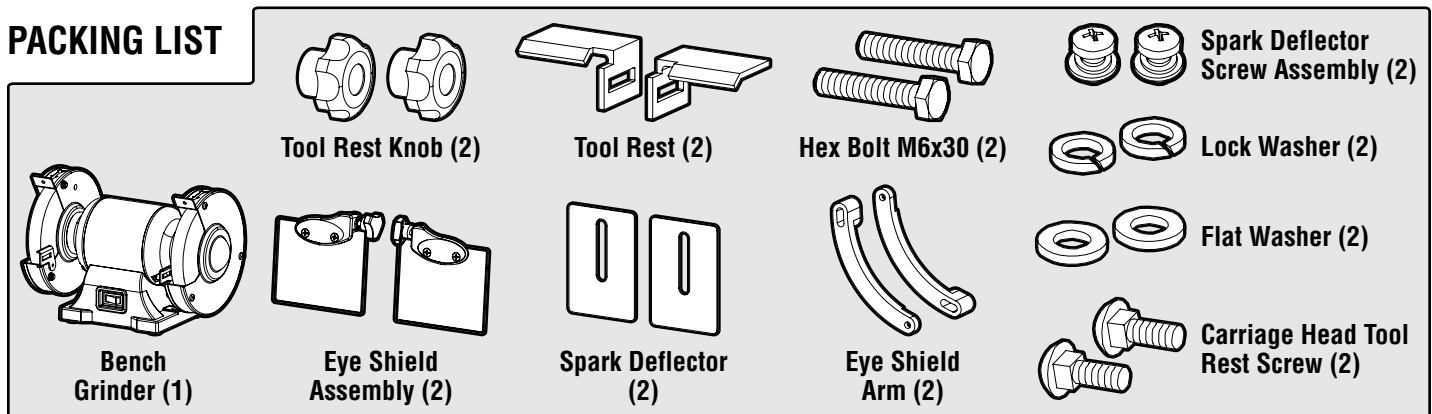

TRANSPORTING

When transporting the bench grinder, carry it by the base. Never carry the tool by its guards or its accessories.

KNOW YOUR BENCH GRINDER

TOOL PURPOSE

This bench grinder features two 6-inch grinding wheels for sharpening dull blades, wood chisels, knives, scissors, carving tools, axes and more. Refer to the following diagrams to become familiarized with all the parts and controls of your bench grinder. The components will be referred to later in the manual for assembly and operation instructions.

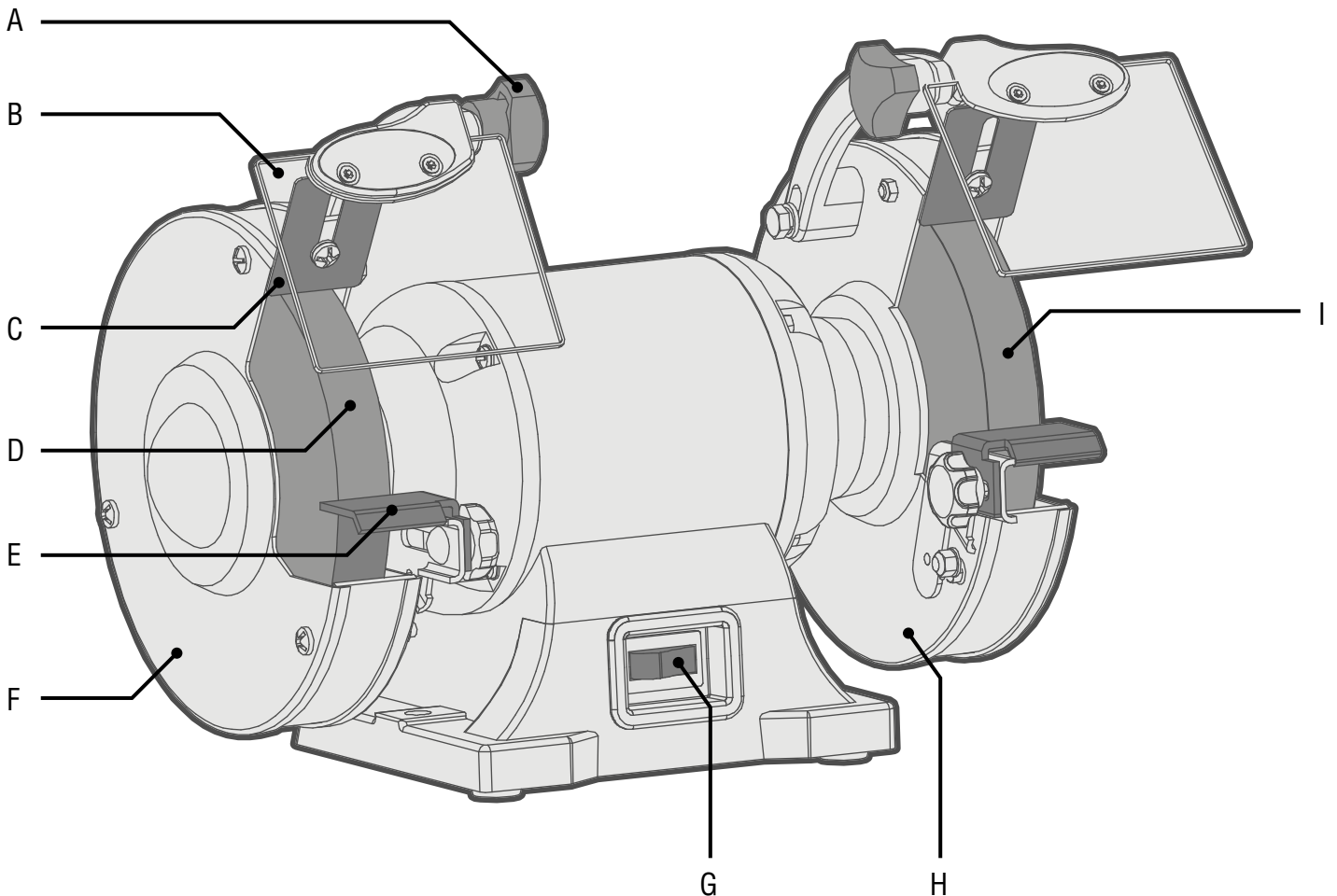

- A. Locking Knob:** Used to adjust the position of the eye shield.
- B. Eye Shield:** Transparent shields to protect you from debris during operation.
- C. Spark Deflector:** Protects you from sparks during operation.
- D. 36-Grit Coarse Grinding Wheel:** Used to quickly remove material.
- E. Tool Rest:** Used to support the workpiece during grinding.

- F. Wheel Cover:** Covers the grinding wheel to protect you from accidental contact and provides quick access for maintenance.
- G. Power Switch:** Use this switch to turn the bench grinder ON and OFF.
- H. Inner Wheel Cover:** Covers the grinding wheel to protect you from accidental contact.
- I. 60-Grit Grinding Wheel:** Used for medium material removal and general purpose grinding.

ASSEMBLY & ADJUSTMENTS

⚠ WARNING! Do not plug in or turn on the tool until it is fully assembled according to the instructions. Read through and become familiarized with the following procedures of handling and adjusting your tool. Failure to follow the safety instructions may result in serious personal injury.

POSITIONING THE MACHINE

Place the machine on a stable, flat work surface. The machine has four rubber feet pre-installed to increase stability and reduce vibration. Make sure there is sufficient open space around the machine. Route the power cord so that it will not make contact with the bench grinder's moving parts.

INSTALLING THE TOOL RESTS (FIG. 2)

1. Place the left tool rest (A) over the tool rest bracket (C) and align the slots.
2. Slide the carriage head tool rest screw (B) through from the left side. Screw the tool rest knob (D) onto the carriage head bolt to hold the tool rest in place.
3. Adjust the tool rest within 1/16 inch of the grinding wheel. **To adjust:** loosen the knob, shift the tool rest, then, tighten the knob.
4. Repeat on the right side.

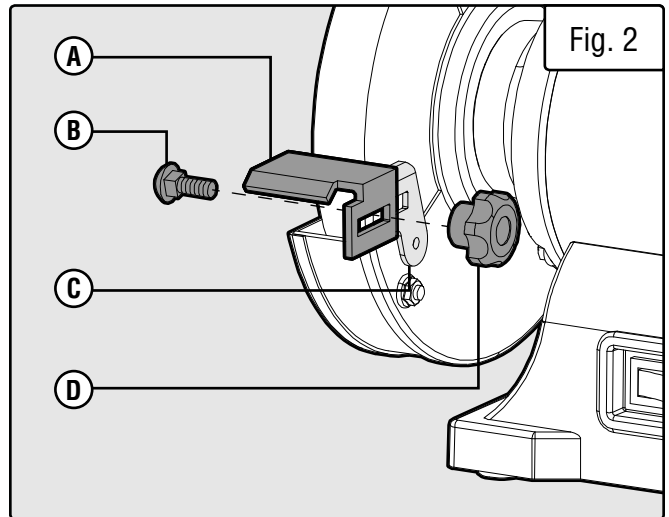

INSTALLING THE SPARK DEFLECTOR (FIG. 3)

1. Place the spark deflector (B) against the left wheel guard (A) (with the thick portion on the bottom). Align the slot with the hole on the wheel guard. Adjust the spark deflector within 1/16 inch of the grinding wheel.
2. Use a Phillips-head screwdriver to secure the pieces together with the spark deflector screw assembly (C).

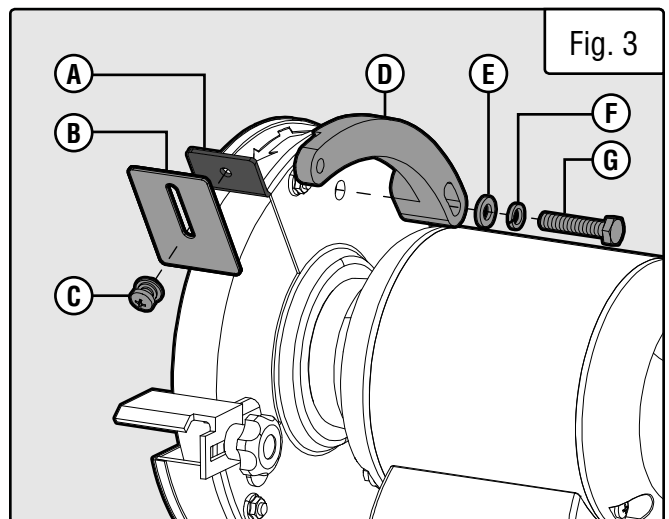

INSTALLING THE EYE SHIELD ARM (FIG. 3)

1. Attach the left shield arm (D) to the inner left wheel guard using a bolt (G), lock washer (F), and flat washer (E) to secure it into place.
2. Repeat on the right side.

INSTALLING THE EYE SHIELD (FIG. 4)

1. Attach the left eye shield (A) to the left shield arm and tighten the locking knob (B) to hold the shield in place.
2. Repeat on the right side.

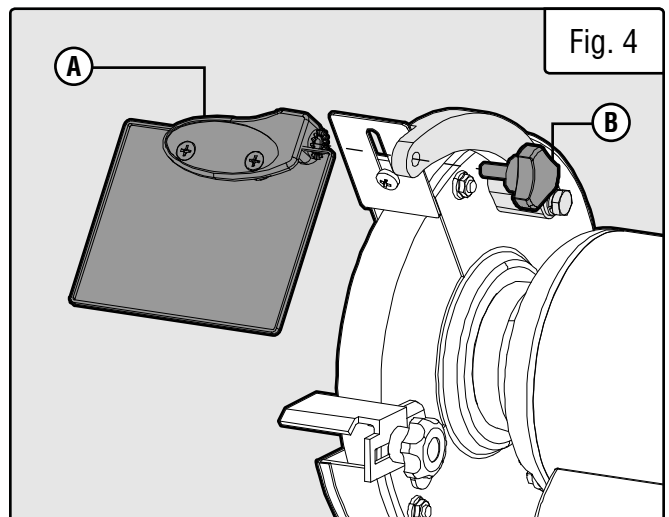

ASSEMBLY & ADJUSTMENTS

 **WARNING!** Always make sure your bench grinder is securely mounted to a workbench or stand. Failure to do so could result in an accident resulting in possible serious personal injury.

MOUNTING YOUR BENCH GRINDER

The bench grinder should be firmly attached to a reliable work surface using mounting hardware (not included) through the base of the grinder's mounting holes. This will prevent the bench grinder from vibration, walking, or tipping during operation.

1. Prepare 1/4 inch bolts, flat washers, lock washers, and hex nuts (not included). The bolt length should be 1-1/2 inches longer than the thickness of the workbench.

2. Locate and mark the holes where the grinder is to be mounted onto the work surface. If mounting to a workbench, drill four 3/8 inch diameter holes through the workbench.

3. Place the bench grinder onto the work surface, aligning holes in base with holes in the workbench. Insert four 1/4 inch diameter bolts and washers. Secure with nuts.

TIP: This bench grinder is compatible with the WEN Cast Iron Bench Grinder Pedestal Stand (Model No. 4288). To purchase, visit wenproducts.com.

OPERATION

 **WARNING!** Do not plug in or turn on the tool until it is fully assembled according to the instructions. Read through and become familiarized with the following procedures of handling and adjusting your tool. Failure to follow the safety instructions may result in serious personal injury.

PRE-OPERATION CHECKLIST

Prior to starting your bench grinder, check that the following requirements have been met:

- PERSONAL PROTECTION** - ANSI Z87.1-approved safety glasses, work-appropriate clothing, and dust mask are being worn.
- GRINDING WHEEL** - the grinding wheel has been properly installed, and can be rotated smoothly by hand. The wheel surface is even.
- TOOL REST SET UP** - the tool rest has been properly installed.
- EYE SHIELD & SPARK DEFLECTOR** - the eye shield and spark deflector have been properly installed.

BASIC OPERATION NOTES

- Your bench grinder has a **60-grit wheel** for medium material removal and **general purpose** grinding, and a **36-grit coarse wheel** for **fast material removal**.
- Turn ON while standing on the side of the grinder, not in front. Allow it to reach full speed before grinding.
- Hold the work piece firmly against the tool rest. Hold very small pieces with pliers or other suitable clamps.
- Feed the work piece smoothly and evenly into the grinding wheel.
- Move the work piece slowly and avoid jamming the work piece against the wheel. If the wheel tends to slow down from excessive force, you should occasionally release the pressure to let the wheel return to full speed.
- Grind only on the face of the grinding wheel and never the side of it.

OPERATION

 **WARNING!** Metal pieces become heated quickly during grinding, so make sure to move the workpiece back and forth to prevent overheating.

 **DANGER!** FIRE HAZARD. Do not grind or polish magnesium or magnesium alloys.

NOTE: Do not apply excessive pressure. Guide the blade with light pressure. Let the grinding wheel do the work.

SHARPENING SCISSORS

If possible, take the scissors apart to make the sharpening operation easier and safer. Remove material only from the outside surface and work from the heavy end of the blade toward the tip.

SHARPENING SCREWDRIVERS

The end of a properly sharpened screwdriver will be a perfect rectangle, absolutely flat and perpendicular to the center line of the shank. The two sides and two faces will taper outward from the edge of the shoulder or shank. They should be flat with intersecting faces perpendicular. Hold each face of the screwdriver against the wheel to true it up, and then ease the end straight into the stone to grind it true.

SHARPENING KNIVES

Remove metal from both faces of most knives, working from the heavy end of the blade toward the tip.

LAWN MOWER BLADES

Lawn mower blades are usually sharpened on only one side and dressed up slightly on the other. After sharpening, be sure to balance the blade by removing additional material from the heavy end. (There are a number of inexpensive cone balancers on the market for this purpose). Unbalanced blades can cause serious crank shaft damage to your lawn mower. Always remove spark plug wires from the mower before servicing the blades to prevent accidental starting.

TROUBLESHOOTING GUIDE

 **WARNING!** Stop using the tool immediately if any of the following problems occur. Repairs and replacements should only be performed by an authorized technician. For any questions, please contact our customer service at (800) 232-1195, M-F 8-5 CST or email us at techsupport@wenproducts.com.

PROBLEM	POSSIBLE CAUSE	SOLUTION
Motor does not start.	1. Power cord or extension cord damaged or not properly plugged in.	1. Check the power cord, extension cord, power plug, and the power outlet. Make sure the tool is properly plugged in. Do not use the tool if any cord is damaged.
	2. Low voltage.	2. Check that the circuit is providing 120V power.
	3. Defective power switch, defective motor or wiring, defective capacitor, short circuit, or loose connections.	3. Stop using the tool and call 1-800-232-1195 for customer service.

Troubleshooting continues on the next page.

TROUBLESHOOTING GUIDE

PROBLEM	POSSIBLE CAUSE	SOLUTION
Motor overheats.	1. Motor overloaded.	1. Reduce load on motor – reduce pressure on workpiece.
	2. Extension cord too long, or of insufficient gauge.	2. Utilize an extension cord of appropriate gauge and length, or plug tool directly into outlet (see page 8).
Grinding wheel not rotating smoothly or evenly.	1. Wheel is improperly installed.	1. Re-install the wheel according to the instructions on page 14.
	2. Wheel is worn out or imbalanced.	2. Replace wheel.
	3. Spindle is not straight.	3. Stop using the tool and call 1-800-232-1195 for customer service.
Wavy finish on the surface of a workpiece.	1. Machine is vibrating.	1. Make sure the machine is securely positioned on a level surface.
	2. Workpiece is not held in place firmly.	2. Make sure you are holding the workpiece or jig firmly.
	3. Wheel face is uneven.	3. Dress grinding wheel according to the instructions on page 14.

MAINTENANCE

 **WARNING!** To avoid accidents, turn OFF and unplug the tool from the electrical outlet before cleaning, adjusting, or performing any maintenance work.

ROUTINE INSPECTION

Before each use, inspect the general condition of the tool. If any of these following conditions exist, do not use until parts are replaced or the tool is properly repaired.

Check for:

- Loose hardware,
- Misalignment or binding of moving parts,
- Damaged cord/electrical wiring,
- Cracked or broken parts, and
- Any other condition that may affect its safe operation.

CLEANING & STORAGE

CAUTION! Most plastics are susceptible to damage from various types of commercial solvents. Do not use any solvents or cleaning products that could damage the plastic parts. Some of these include but are not limited to: gasoline, carbon tetrachloride, chlorinated cleaning solvents, and household detergents that contain ammonia.

1. Keep the ventilation openings free from dust and debris to prevent the motor from overheating.

Maintenance continues on the next page.

MAINTENANCE

2. Use a vacuum or low-pressure compressed air to remove dust and debris from the tool surfaces, motor housing and work area.
3. Wipe the tool surfaces clean with a soft cloth or brush. Make sure water does not get into the tool.
4. Store the tool in a clean and dry place away from the reach of children. Store in temperatures between 41° to 86°F.
5. Cover the tool in order to protect it from dust and moisture. It is preferable to store it in its original packaging with the instruction manual and all accessories.

LUBRICATION

All bearings on your bench grinder are permanently lubricated and require no additional lubrication.

DRESSING THE GRINDING WHEEL

Dress the grinding wheel periodically using dressing tools (sold separately) to restore or adjust the wheel's abrasiveness. Follow the instructions that are included with your dressing tools and accessories to properly dress the grinding wheel.

Using a dressing stone with a coarse/smooth face:

- To remove larger amount of materials quickly, dress the wheel for coarse grinding. Apply the coarse face of the dressing stone to the grinding wheel to roughen the wheel's surface.
- For fine grinding, apply the smooth face of the dressing stone to the grinding wheel to create a finer surface.

REPLACING THE GRINDING WHEEL

Grinding wheels should be inspected for any damage or cracking before each use. Store the grinding wheels to prevent them from the potential hazards of moisture, containments and other damage. Replacement 6-inch grinding wheels (Part No's 4276-015 and 4276-036) can be purchased from wenproducts.com.

To replace a grinding wheel:

1. Turn OFF and disconnect the bench grinder from the power supply.
2. Use a Phillips-head screwdriver (not included) to loosen the three screws on the grinding wheel cover and remove it.
3. Hold the grinding wheel to prevent it from rotating. Remove the lock nut with a 19mm wrench (not included).

NOTE: The lock nuts are self-tightening. The left wheel is left-hand threaded and the right wheel is right-hand threaded. This means that on the left wheel you turn the nut right to loosen, and on the right wheel you turn the nut left to loosen.

4. Remove the outer flange and the wheel. Place the new wheel onto the spindle.
5. Replace the outer flange (so the large ring surface touches the wheel) and the lock nut. Tighten the lock nut by hand. Snug it up with a wrench if desired.

⚠ WARNING! NEVER use an impact driver or impact wrench to tighten the nuts. An overtightened nut could crack the grinding wheel and cause a hazard.

6. Replace the wheel cover and secure with screws.

PRODUCT DISPOSAL

Used power tools should not be disposed of together with household waste. This product contains electronic components that should be recycled. Please take this product to your local recycling facility for responsible disposal and to minimize its environmental impact.



Please recycle the packaging and electronic components where facilities exist.

EXPLODED VIEW & PARTS LIST

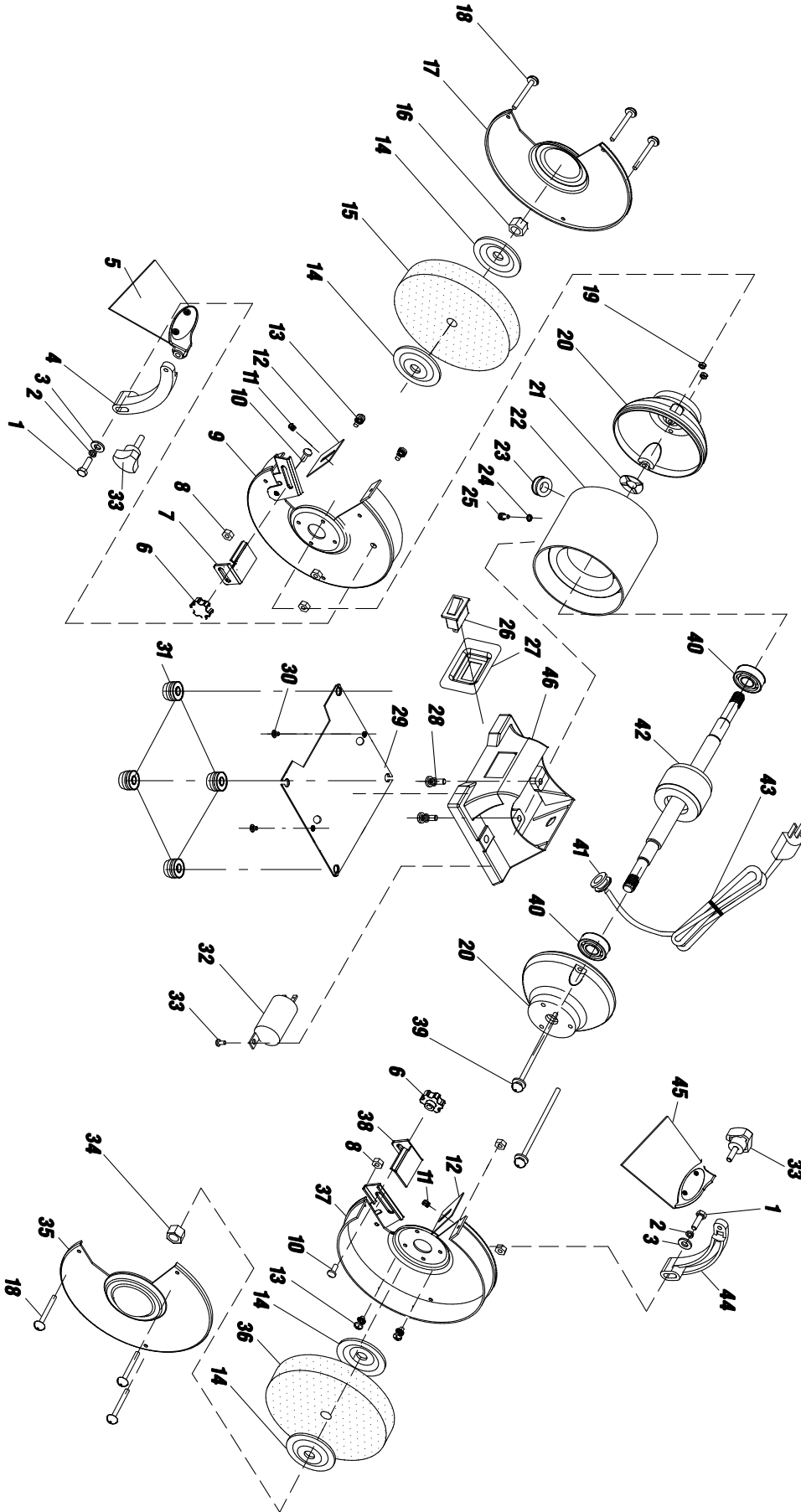

EXPLODED VIEW & PARTS LIST

No.	Part No.	Description	Qty.
1	4276-001	Bolt, M6x30	2
2	4276-002	Spring Washer, 6mm	2
3	4276-003	Flat Washer, 6mm	2
4	4276-004	Left Eye Shield Bracket	1
5	4276-046	Left Eye Shield Assembly	1
6	4276-006	Tool Rest Lock Knob (M6)	2
7	4276-007	Left Work Rest	1
8	4276-008	Nut, M5	6
9	4276-009	Left Guard	1
10	4276-010	Carriage Bolt, M6x14	2
11	4276-011	Fastener Assembly, M5x10	2
12	4276-012	Spark Deflector	2
13	4276-013	Fastener Assembly, M5x10	4
14	4276-014	Flange	4
15	4276-015	Grinding Wheel, 36-grit	1
16	4276-016	Hex Nut, M12-LH	1
17	4276-017	Left Wheel Guard Cover	1
18	4276-018	Screw, M5x42	6
19	4276-019	Nut, M4	2
20	4276-020	End Bell	2
21	4276-021	Wavy Washer, 34.5mm	1
22	4276-022	Stator	1
23	4276-023	Power Cord Bushing	1
24	4276-024	Toothed Washer, 4mm	1
25	4276-025	Fastener Assembly, M4x8	1
26	4276-026	Switch	1
27	4276-027	Switch Plate	1

No.	Part No.	Description	Qty.
28	4276-028	Fastener Assembly, M6x18	2
29	4276-029	Bottom Plate	1
30	4276-030	Fastener Assembly, M4x6	2
31	4276-031	Rubber Feet	4
32	4276-032	Capacitor	1
33	4276-48	Eye Shield Locking Knob	2
34	4276-034	Nut, M12-RH	1
35	4276-035	Right Wheel Guard Cover	1
36	4276-036	Grinding Wheel, 60-grit	1
37	4276-037	Right Wheel Guard	1
38	4276-038	Right Work Rest	1
39	4276-039	Fastener Assembly, M4x18	2
40	4276-040	Ball Bearing, 6202	2
41	4276-041	Cord Clamp	1
42	4276-042	Rotor	1
43	4276-043	Power Cord	1
44	4276-044	Right Eye Shield Bracket	1
45	4276-045	Right Eye Shield Assembly	1
46	BG4266-046	Base	1

WARRANTY

WEN Products is committed to building tools that are dependable for years. Our warranties are consistent with this commitment and our dedication to quality.

LIMITED WARRANTY OF WEN PRODUCTS FOR HOME USE

GREAT LAKES TECHNOLOGIES, LLC (“Seller”) warrants to the original purchaser only, that all WEN consumer power tools will be free from defects in material or workmanship during personal use for a period of two (2) years from date of purchase or 500 hours of use; whichever comes first. Ninety days for all WEN products if the tool is used for professional or commercial use. Purchaser has 30 days from the date of purchase to report missing or damaged parts.

SELLER’S SOLE OBLIGATION AND YOUR EXCLUSIVE REMEDY under this Limited Warranty and, to the extent permitted by law, any warranty or condition implied by law, shall be the replacement of parts, without charge, which are defective in material or workmanship and which have not been subjected to misuse, alteration, careless handling, misrepair, abuse, neglect, normal wear and tear, improper maintenance, or other conditions adversely affecting the Product or the component of the Product, whether by accident or intentionally, by persons other than Seller. To make a claim under this Limited Warranty, you must make sure to keep a copy of your proof of purchase that clearly defines the Date of Purchase (month and year) and the Place of Purchase. Place of Purchase must be a direct vendor of Great Lakes Technologies, LLC. Purchasing through third party vendors, including but not limited to garage sales, pawn shops, resale shops, or any other secondhand merchant, voids the warranty included with this product. Contact tech-support@wenproducts.com or 1-800-232-1195 with the following information to make arrangements: your shipping address, phone number, serial number, required part numbers, and proof of purchase. Damaged or defective parts and products may need to be sent to WEN before the replacements can be shipped out.

Upon the confirmation of a WEN representative, your product may qualify for repairs and service work. When returning a product for warranty service, the shipping charges must be prepaid by the purchaser. The product must be shipped in its original container (or an equivalent), properly packed to withstand the hazards of shipment. The product must be fully insured with a copy of the proof of purchase enclosed. There must also be a description of the problem in order to help our repairs department diagnose and fix the issue. Repairs will be made and the product will be returned and shipped back to the purchaser at no charge for addresses within the contiguous United States.

THIS LIMITED WARRANTY DOES NOT APPLY TO ITEMS THAT WEAR OUT FROM REGULAR USAGE OVER TIME, INCLUDING BELTS, BRUSHES, BLADES, BATTERIES, ETC. ANY IMPLIED WARRANTIES SHALL BE LIMITED IN DURATION TO TWO (2) YEARS FROM DATE OF PURCHASE. SOME STATES IN THE U.S. AND SOME CANADIAN PROVINCES DO NOT ALLOW LIMITATIONS ON HOW LONG AN IMPLIED WARRANTY LASTS, SO THE ABOVE LIMITATION MAY NOT APPLY TO YOU.

IN NO EVENT SHALL SELLER BE LIABLE FOR ANY INCIDENTAL OR CONSEQUENTIAL DAMAGES (INCLUDING BUT NOT LIMITED TO LIABILITY FOR LOSS OF PROFITS) ARISING FROM THE SALE OR USE OF THIS PRODUCT. SOME STATES IN THE U.S. AND SOME CANADIAN PROVINCES DO NOT ALLOW THE EXCLUSION OR LIMITATION OF INCIDENTAL OR CONSEQUENTIAL DAMAGES, SO THE ABOVE LIMITATION OR EXCLUSION MAY NOT APPLY TO YOU.

THIS LIMITED WARRANTY GIVES YOU SPECIFIC LEGAL RIGHTS, AND YOU MAY ALSO HAVE OTHER RIGHTS WHICH VARY FROM STATE TO STATE IN THE U.S., PROVINCE TO PROVINCE IN CANADA AND FROM COUNTRY TO COUNTRY.

THIS LIMITED WARRANTY APPLIES ONLY TO ITEMS SOLD WITHIN THE UNITED STATES OF AMERICA, CANADA AND THE COMMONWEALTH OF PUERTO RICO. FOR WARRANTY COVERAGE WITHIN OTHER COUNTRIES, CONTACT THE WEN CUSTOMER SUPPORT LINE. FOR WARRANTY PARTS OR PRODUCTS REPAIRED UNDER WARRANTY SHIPPING TO ADDRESSES OUTSIDE OF THE CONTIGUOUS UNITED STATES, ADDITIONAL SHIPPING CHARGES MAY APPLY.

**THANKS FOR
REMEMBERING**

