



# OPERATION and MAINTENANCE MANUAL

BLUE M

**STABIL-THERM®**

Bench Type  
Gravity Convection

**LABORATORY OVEN**



MODEL OV-12A



**BLUE M** *Electric Company*

CORPORATE HEADQUARTERS: BLUE ISLAND, ILLINOIS 60406

## OPERATION AND MAINTENANCE

# BLUE M STABIL-THERM®

Bench Type  
Gravity Convection

# LABORATORY OVEN

MODEL OV-12A

### I. INTRODUCTION

When oven is used for operations such as pre-heating or heat soaking, it may be loaded somewhat indiscriminately and a large volume of work space may be used. Care should be taken that shelf areas are not completely blocked. **UNDER NO CIRCUMSTANCES** should work be placed on diffuser plate at bottom of oven. Heat is radiated upward from bottom to top in this oven and large temperature differences will result if air flow is blocked. If flat sheets are to be processed, they should be placed in a vertical position.

**CAUTION:** The heating elements in this oven are exposed to interior work chamber. Avoid spilling or setting any material on elements.

For more critical applications, upper two-thirds of the oven is most stable zone; here, heated air from elements has diffused with air in work chamber to provide stable temperature. Check temperature of this area as close to test load as possible with accurate thermometer or pyrometer. Allow temperature to stabilize (approximately one hour without temperature change) before checking.

**WARNING:** This oven is not suitable for processing flammable solvents of any type. Contact factory concerning such applications.

### II. INSTALLATION

All standard Blue M Ovens are shipped electrically complete. Positioning oven and connecting proper electrical supply are the only requirements to put into operation.

A. When installing oven, allow sufficient air space between oven walls and building walls and/or flammable materials. Consideration must also be given to existing wiring. An oven will raise ambient temperature around it.

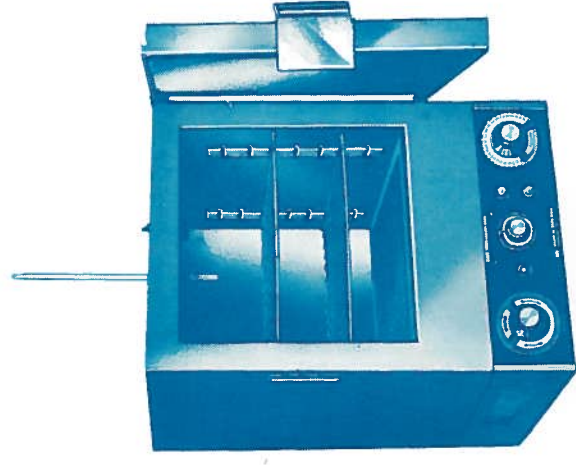

**NOTE: DO NOT CONNECT OVEN TO ALREADY OVERLOADED POWER LINES. EXCESSIVE VOLTAGE DROP WILL ADVERSELY AFFECT OPERATION.**

B. Plug line cord in power source (voltage and frequency specified on data plate). Line cord plug and receptacle are considered sufficient disconnect if visible and readily accessible to operator.

C. Line cord is provided with a three prong plug. Oven is grounded when plugged in.

**NOTE: DO NOT CONNECT POWER LINE NEUTRAL TO OVEN FOR GROUNDING PURPOSES.**

D. Fused protection should not exceed 125% of oven rating.

**NOTE: IF ABOVE INFORMATION IS IN CONFLICT WITH LOCAL CODES, ADHERE TO LOCAL CODES.**

### III. OPERATING CONTROLS AND FEATURES (See Figure 1)

A. MAIN PILOT LIGHT indicates power being supplied to oven.

B. HEATER PILOT LIGHT cycles on and off with heating elements.

C. POWER SELECTOR SWITCH is used in conjunction with TEMPERATURE CONTROL to regulate operating temperature. Settings are OFF, LOW, MEDIUM, and HIGH. LOW supplies temperatures up to approximately 120° C (248° F), MEDIUM setting from 120° C to 180° C (356° F), HIGH setting from 180° C to maximum. Use lowest setting possible to maintain desired temperature. These settings may vary according to load mass and position of vents.

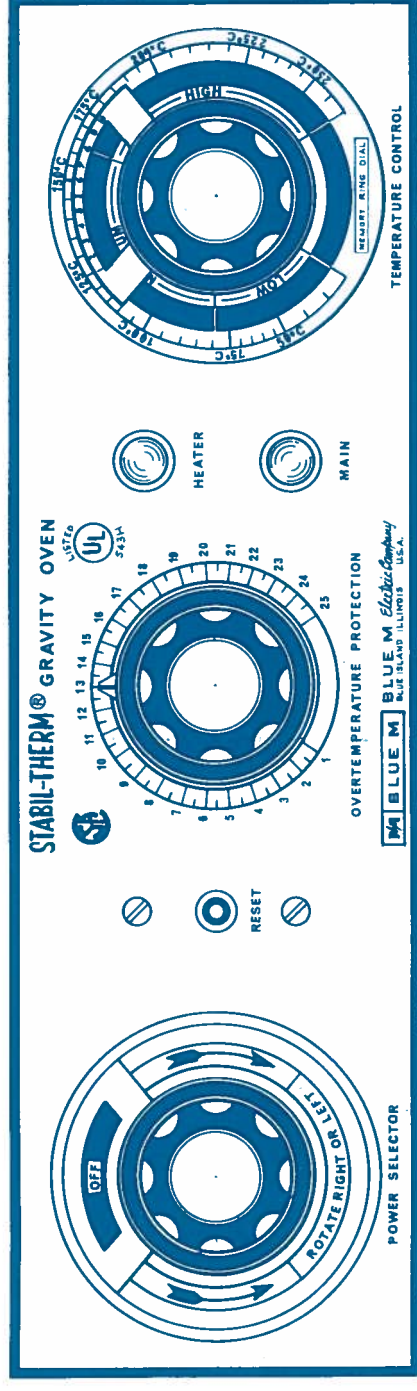

Figure 1

D. TEMPERATURE CONTROL is a direct acting thermostat. As temperature of sensing bulb is raised, fluid in system expands forcing diaphragm outward. Motion of diaphragm opens or closes electrical contacts controlling power to heating elements.

E. TEMPERATURE INDICATOR is a mercury filled glass thermometer inserted into top of oven.

F. INTAKE AND EXHAUST VENTS provide for flow of air through oven. Exhaust vents are adjustable to vary flow of air, (See Figure 2). Exhaust vents are normally closed, which allows most efficient operation. There are some operations which benefit from opening vents, i.e., venting of vapors formed during tests; providing slow cool-down; and to provide ducts for electrical connections to load. See Section VII.

G. OVERTEMPERATURE PROTECTION (OTP) SYSTEM protects load and oven by shutting down oven if temperature exceeds a set level.

H. RESET BUTTON — press to reset OTP device.

### IV. OPERATION

A. Set POWER SELECTOR SWITCH to desired setting (See Section III, C., above). POWER SELECTOR acts as ON/OFF switch.

B. Set TEMPERATURE CONTROL to desired temperature (See Section V).

C. Set OTP (See Section VI).

D. Adjust vents as needed (See Section VII).

E. Oven should operate normally.

### V. USING THE MEMORY RING DIAL® AND REFERENCE NUMBERS (See Figure 3)

The patented Memory Ring Dial System allows accurate and repeatable settings to be easily made; it also allows correction factors to be entered into control system. For proper use proceed as follows:

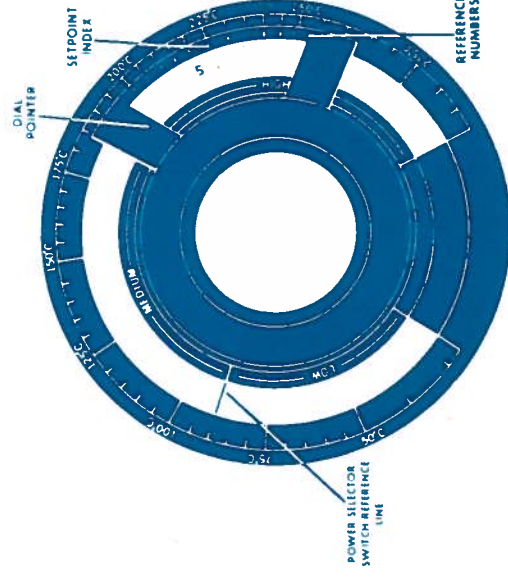

Figure 3

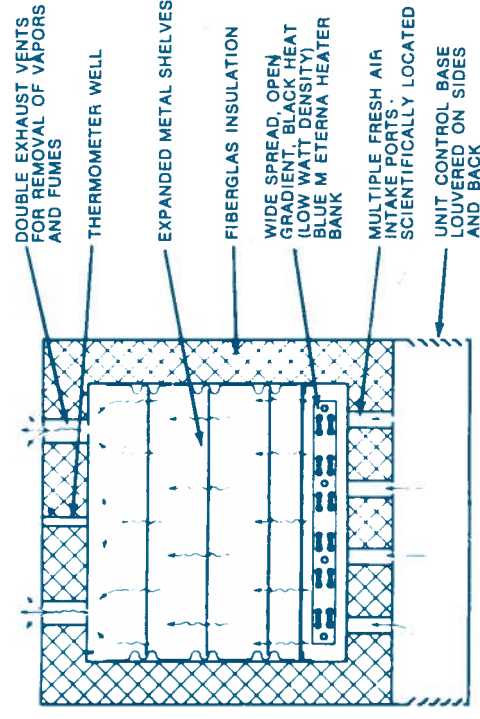

Figure 2

- A. Rotate control knob so that setpoint index line (located between reference numbers 5 and 6) lines up with the desired temperature (+220° C., in this case). Power Selector Switch reference line will indicate which range to set Power Selector; medium, in this case.
- B. Allow oven to stabilize (approximately one hour without temperature change).
- C. If thermometer does not agree with dial setting, rotate dial slightly in desired direction and allow oven to stabilize.
- D. After unit has stabilized at +220° C., note which reference number lines up with +220° C. (In this example, assume number 5 lines up). See Figure 3.
- E. Write, in pencil, number 5 in white ring exactly under +220° C. mark.
- F. In future, when +220° C. is dialed, correction number 5 will appear in correction window. This will indicate that number 5 is the correction number for +220° C.
- G. All other points may be calibrated in same manner. Temperatures may be calibrated in normal use by marking a correction number when proper temperature is reached.

**NOTE:** IF ANY DESIRED TEMPERATURE CANNOT BE ACCOMMODATED WITHIN THE POINTER WINDOW, RECALIBRATION IS NEEDED. SEE SECTION VII.

#### VI. OPERATION OF OTP (See Figure 1)

**NOTE:** OTP must be set higher than internal temperature of unit or oven will not operate.

- A. Max-Set OTP is supplied with dial graduated in reference numbers; each number represents approximately 10° C. When calibrating OTP, turn knob fully clockwise. When oven has stabilized at desired temperature (1 hour), slowly rotate knob counterclockwise until MAIN PILOT LIGHT and HEATER PILOT LIGHT switch off. This indicates that OTP has shut oven down, and is functioning properly. Make a note at which reference number OTP trips, and rotate OTP knob fully clockwise then back (counterclockwise) to one reference number higher than point where OTP trips. Pilot lights should go on and oven should be ready for operation. (It may be necessary to press reset button).
- B. Occasionally, turn MAIN TEMPERATURE CONTROL up above OTP setting to verify proper functioning of OTP should main control fail. When MAIN CONTROL setting exceeds OTP setting, oven should shut down.

#### VII. INTAKE AND EXHAUST VENTS provide for flow of air through oven. Exhaust vents are adjustable.

(See Figure 2). Normally, exhaust vents should be left closed. This will provide quicker run up to operating temperature, and more economical use. However, there are three circumstances when opening vents is recommended.

- A. REMOVAL OF VAPORS WHICH ARE A RESULT OF HEATING PROCESS. When material in oven is to be dried, drying will take place more rapidly if the vents are slightly or completely open. This technique may also be used to exhaust noxious or volatile fumes which result from some processes.

**WARNING:** This oven should not be used in such a manner that will create explosive fumes or vapors. The venting of explosive vapors does NOT convert standard oven to Hazard Safe Specifications.

- B. Provides SLOW COOL-DOWN AND PREVENTS HEAT SHOCK. Some loads may be damaged by heat shock when door is opened for removal. This can be avoided by opening exhaust vents and allowing load to cool slowly in oven, with heat turned off.
- C. PROVIDE ENTRANCE FOR ELECTRICAL AND OTHER CONNECTIONS TO LOAD DURING TEST. It is recommended that ports designed for the above purpose be installed if such connections are frequently used. Contact factory for information.

#### VIII. MAINTENANCE

If measured temperature is in error or a set temperature cannot be maintained, check the following:

- A. Check all fuses.
- B. Check line voltage; excessive voltage drop will affect oven operation.
- C. Check all electrical connections.
- D. Inspect control sensing bulb for damage or deterioration.
- E. Inspect door seal for leaks; gasket should be replaced after 2 to 3 years normal service.
- F. Inspect heating elements for continuity and deterioration. (See Wiring Diagram for element resistance). To remove elements;
  1. Disconnect power to oven.
  2. Lay oven on its side and remove screws that secure bottom cover. Cover will bow and may be pulled out.
  3. Remove element wires from terminals on ceramic blocks inside bottom compartment.
  4. Remove two screws located on wire mesh diffuser plate covering element inside chamber.
  5. Carefully remove wire mesh diffuser plate and then bend control sensing bulb away.
  6. Loosen two nuts on threaded shafts supporting element inside oven and turn back approximately 1/2 inch.



7. Slide element forward and out.

8. Reverse procedure for reinstallation.

G. If OTP should malfunction, check OTP thermostat. Contacts should be closed when control is above setpoint and open when below setpoint temperature.

H. Check time delay resistor and manual reset thermostat. Manual reset thermostat is a heat-sensitive device which relies on heat from time delay resistor to activate it. If resistor is set too close, thermostat will trip too rapidly; if set too far away, it will never trip. Proper resistor spacing is from 1/16" to 1/8" away from back of thermostat.

I. To gain access to back of panel, remove screws holding panel to base, and pull panel forward.

**NOTE: POWER MUST BE DISCONNECTED FROM OVEN BEFORE REMOVING PANEL.**

#### IX. CALIBRATING MEMORY RING DIAL

All dials are factory calibrated at a mid-range temperature; this calibration should suffice for six months to a year of normal use. When control needs to be recalibrated, proceed as follows:

A. Calibrate dial at some mid-scale temperature. For controls having +260° C. maximum, +150° C. is normally used.

B. With thermometer installed (2" to 4" inside oven), set power selector as per reference line on temperature control. In example with setpointer index pointer at +150° C., power selector index line is lined up with MEDIUM.

C. Allow oven to operate (approximately one hour).

D. With temperature stabilized, loosen set screws on control knob, being careful not to rotate knob.

E. Rotate knob slowly until pointer index line points to exact temperature indicated on thermometer.

F. Tighten set screws with knob in position.

**NOTE: THERE IS A STRONG SPRING IN BACK OF CONTROL KNOB. WHEN SET SCREWS ARE LOOSENED, SPRING WILL TEND TO PUSH KNOB OFF SHAFT.**

G. Allow oven to stabilize (15 minutes) and check to be sure temperature setting was not changed during calibration. If not, calibration is complete; if setting was disturbed, recalibrate.

#### X. CARE AND CLEANING OF STAINLESS STEEL

A. On outside surfaces only, clean with soft cloth wrung out in mild soapy solution; wipe dry with cloth dipped in clean water.

B. Once a month, scour outside surfaces only with a scouring compound that will not mar surface. Tarsuric acid may also be used. The use of stainless steel wool is acceptable, but do not use ordinary steel wool as it will damage the surface.

C. Grease and oils may be removed by using vapor degreasing solution or other solvent.

**CAUTION: DO NOT USE FLAMMABLE SOLVENTS ON OR NEAR HOT OVENS. SOLVENT FUMES ARE DANGEROUS AND MAY IGNITE.**

#### XI. CARE OF THERMOMETERS — GLASS TYPE

Mercury column may become separated in shipment. To reunite, proceed as follows:

A. Heat thermometer until main mercury column and separate particles reach expansion chamber at top of stem.

B. Tap gently until all mercury is united. Cool in vertical position.

#### FACTORY GUARANTEE / WARRANTY

Heating elements are warranted to be free of manufacturing and material defects for a period of two years. All other components, including control systems, cabinets, etc., are warranted for one year. Warranty does not cover damage or failure caused by abuse, misuse, abnormal usage, faulty installation, improper maintenance, or any repairs other than those made by authorized Blue M service personnel. Warranty is not transferable. Collect shipments are not accepted at factory without written or verbal permission from authorized personnel; Blue M reserves the right to invoice for these collect charges.

## CATALOG SPECIFICATIONS

MODEL NUMBER	INSIDE DIMENSIONS (Inches)			MAXIMUM WATTS	VOLTAGE 50/60 Hz. SINGLE PHASE	TEMPERATURE RANGE
	W	D	H			
OV-12A	12	12	12	975	120 V.	+38° C. to +260° C. (+100° F. to +500° F.)

### WIRING DIAGRAM

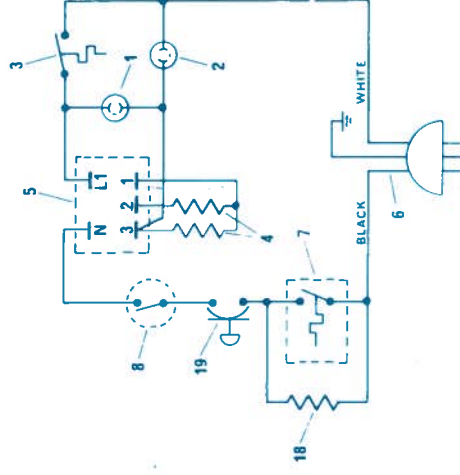

### REPLACEMENT PARTS LIST — MODEL OV-12A

ITEM NUMBER	DESCRIPTION	PART NUMBER	QUANTITY
1	Control Pilot (Amber)	E06B-1	1
2	Main Pilot Light (Red)	E06B-2	1
3	Temperature Control	C03A-6-3	1
4	Heating Elements (2 coils, 29.8 Ohms ea.)	A121-273A	1
5	Power Selector Switch	E16D-1	1
6	Line Cord and Plug	E07A-1	1
7	Overtemperature Protection (Control Only)	C03A-6-3	1
8	Spring-Wound Timer, 6 Hour	C12D-3	1
9	Shelf, Stainless Steel	M04-A108	1
10	Thermometer (0° C. to +260° C.)	C01C-3	1
11	Latch and Strike, Chrome-Plated	M02-D1	1
12	S/S Wire Mesh Element Shield	M20-L103	1
13	Exhaust Port Cover	M11-B1	1
14	Door Gasket	M05-A7-60	As Req'd
15	Autotransformer 240V/120V	E17A-1-2	1
16	Viewing Panel (Glass only)	M14-C4	2
17	Hinges	M01-B5	2
18	Resistor, 750 Ohms	E03A-5-4	1
19	OTP Reset Device	C03C-4-1	1

\* Parts not shown \*\* Optional equipment

PRICES SUBJECT TO CHANGE WITHOUT NOTICE. PARTS SHIPPED F.O.B. BLUE ISLAND, ILL. WHEN ORDERING PARTS GIVE MODEL No., SERIAL No., VOLTAGE AND PART No.



**BLUE M Electric Company**

CORPORATE HEADQUARTERS: BLUE ISLAND, ILLINOIS 60406

MANUFACTURERS AND ORIGINAL DESIGNERS OF CONSTANT TEMPERATURE CONTROLLED EQUIPMENT

OFFICES

BLUE M ELECTRIC COMPANY

CORPORATE HEADQUARTERS: BLUE ISLAND, ILLINOIS 60406

TELEPHONE: (312) 385-9000

ARIZONA-TEMPE  
424 West Broadway 85281  
(602)894-2305

NEW YORK-NANUET  
20 Old Turnpike Rd. 10954  
(914)623-0900

CALIFORNIA-EL MONTE  
9650 Telestar Avenue 91731  
(213)442-6672

NEW YORK-SYRACUSE  
6443 Ridings Road 13206  
(315)437-0192

CALIFORNIA-SUNNYVALE  
1287 Lawrence Station Road 94086  
(408)734-8734

NORTH CAROLINA-CHARLOTTE  
501 Archdale Dr., Box 15291 28210  
(704)527-2492

FLORIDA-ORLANDO  
3001 Aloma Avenue, Room 203 32789  
(305)671-6655

OHIO-CINCINNATI  
1821 Summit Road 45237  
(513)821-6278

GEORGIA-ATLANTA  
3300 Buckeye Road, No.663 30341  
(404)455-3452

PENNSYLVANIA-MALVERN  
Great Valley Center  
81 Lancaster Ave. 19355  
(215)296-8660

ILLINOIS-BLUE ISLAND  
138th and Chatham 60406  
(312)385-9000

MASSACHUSETTS-FRAMINGHAM  
51 New York Avenue 01701  
(617)235-8320

TEXAS-GARLAND  
2301 Forest Lane 75042  
(214)272-2509

MICHIGAN-TAYLOR  
23940 Eureka 48180  
(313)287-3406

WASHINGTON-SEATTLE  
5501 4th Avenue, South 98108  
(206)763-1030



**BLUE M** *Electric Company*