

24259

# 12" Disc Sander with Integral Dust Collection

(Model 31-120)



PART NO. 900657 (011)  
Copyright © 2001 Delta Machinery



To learn more about DELTA MACHINERY  
visit our website at: [www.deltamachinery.com](http://www.deltamachinery.com).

**For Parts, Service, Warranty or other Assistance,**

**please call 1-800-223-7278 (In Canada call 1-800-463-3582).**

**RTD10000119AA**

# SAFETY RULES

Woodworking can be dangerous if safe and proper operating procedures are not followed. As with all machinery, there are certain hazards involved with the operation of the product. Using the machine with respect and caution will considerably lessen the possibility of personal injury. However, if normal safety precautions are overlooked or ignored, personal injury to the operator may result. Safety equipment such as guards, push sticks, hold-downs, featherboards, goggles, dust masks and hearing protection can reduce your potential for injury. But even the best guard won't make up for poor judgment, carelessness or inattention. Always use common sense and exercise caution in the workshop. If a procedure feels dangerous, don't try it. Figure out an alternative procedure that feels safer. REMEMBER: Your personal safety is your responsibility.

This machine was designed for certain applications only. Delta Machinery strongly recommends that this machine not be modified and/or used for any application other than that for which it was designed. If you have any questions relative to a particular application, DO NOT use the machine until you have first contacted Delta to determine if it can or should be performed on the product.

**Technical Services Manager**  
**Delta Machinery**  
**4825 Highway 45 North**  
**P.O. Box 2468**  
**Jackson, TN 38302-2468**  
**(IN CANADA: 505 SOUTHGATE DRIVE, GUELPH, ONTARIO N1H 6M7)**

## **WARNING: FAILURE TO FOLLOW THESE RULES MAY RESULT IN SERIOUS PERSONAL INJURY**

- 1. FOR YOUR OWN SAFETY, READ INSTRUCTION MANUAL BEFORE OPERATING THE TOOL.** Learn the tool's application and limitations as well as the specific hazards peculiar to it.
- 2. KEEP GUARDS IN PLACE** and in working order.
- 3. ALWAYS WEAR EYE PROTECTION.**
- 4. REMOVE ADJUSTING KEYS AND WRENCHES.** Form habit of checking to see that keys and adjusting wrenches are removed from tool before turning it "ON."
- 5. KEEP WORK AREA CLEAN.** Cluttered areas and benches invite accidents.
- 6. DON'T USE IN DANGEROUS ENVIRONMENT.** Don't use power tools in damp or wet locations, or expose them to rain. Keep work area well-lighted.
- 7. KEEP CHILDREN AND VISITORS AWAY.** All children and visitors should be kept a safe distance from work area.
- 8. MAKE WORKSHOP CHILDPROOF** – with padlocks, master switches, or by removing starter keys.
- 9. DON'T FORCE TOOL.** It will do the job better and be safer at the rate for which it was designed.
- 10. USE RIGHT TOOL.** Don't force tool or attachment to do a job for which it was not designed.
- 11. WEAR PROPER APPAREL.** No loose clothing, gloves, neckties, rings, bracelets, or other jewelry to get caught in moving parts. Nonslip footwear is recommended. Wear protective hair covering to contain long hair.
- 12. ALWAYS USE SAFETY GLASSES.** Wear safety glasses. Everyday eyeglasses only have impact resistant lenses; they are not safety glasses. Also use face or dust mask if cutting operation is dusty.
- 13. SECURE WORK.** Use clamps or a vise to hold work when practical. It's safer than using your hand and frees both hands to operate tool.
- 14. DON'T OVERREACH.** Keep proper footing and balance at all times.
- 15. MAINTAIN TOOLS IN TOP CONDITION.** Keep tools sharp and clean for best and safest performance. Follow instructions for lubricating and changing accessories.
- 16. DISCONNECT TOOLS** before servicing and when changing accessories such as blades, bits, cutters, etc.
- 17. USE RECOMMENDED ACCESSORIES.** The use of accessories and attachments not recommended by Delta may cause hazards or risk of injury to persons.
- 18. REDUCE THE RISK OF UNINTENTIONAL STARTING.** Make sure switch is in "OFF" position before plugging in power cord.
- 19. NEVER STAND ON TOOL.** Serious injury could occur if the tool is tipped or if the cutting tool is accidentally contacted.
- 20. CHECK DAMAGED PARTS.** Before further use of the tool, a guard or other part that is damaged should be carefully checked to ensure that it will operate properly and perform its intended function – check for alignment of moving parts, binding of moving parts, breakage of parts, mounting, and any other conditions that may affect its operation. A guard or other part that is damaged should be properly repaired or replaced.
- 21. DIRECTION OF FEED.** Feed work into a blade or cutter against the direction of rotation of the blade or cutter only.
- 22. NEVER LEAVE TOOL RUNNING UNATTENDED. TURN POWER OFF.** Don't leave tool until it comes to a complete stop.
- 23. DRUGS, ALCOHOL, MEDICATION.** Do not operate tool while under the influence of drugs, alcohol or any medication.
- 24. MAKE SURE TOOL IS DISCONNECTED FROM POWER SUPPLY** while motor is being mounted, connected or reconnected.
- 25. WHEN THE UNIT IS NOT IN USE** the switch should be locked in the "OFF" position to prevent unauthorized use.
- 26.  THE DUST GENERATED** by certain woods and wood products can be injurious to your health. Always operate machinery in well ventilated areas and provide for proper dust removal. Use wood dust collection systems whenever possible.
- 27. WARNING: SOME DUST CREATED BY POWER SANDING, SAWING, GRINDING, DRILLING, AND OTHER CONSTRUCTION ACTIVITIES** contains chemicals known to cause cancer, birth defects or other reproductive harm. Some examples of these chemicals

are:

- lead from lead-based paints,
- crystalline silica from bricks and cement and other masonry products, and
- arsenic and chromium from chemically-treated lumber.

Your risk from these exposures varies, depending on how often you do this type of work. To reduce your

## ADDITIONAL SAFETY RULES FOR DISC SANDERS

1. **READ AND UNDERSTAND INSTRUCTION MANUAL BEFORE OPERATING DISC SANDER.**
2. **IF YOU ARE NOT** thoroughly familiar with the operation of Disc Sanders, obtain advice from your supervisor, instructor or other qualified person.
3. **MAKE SURE** wiring codes and recommended electrical connections are followed and that machine is properly grounded.
4. **MAINTAIN** maximum clearance of 1/16" between table and sanding belt or disc.
5. **THIS TOOL** is intended for indoor use only.
6. **MAKE SURE** the abrasive disc is not torn or loose.
7. **ALWAYS** keep hands away from abrasive surfaces.
8. **HOLD** the work firmly when sanding.
9. **NEVER** wear gloves or hold the work with a rag when sanding.
10. **AVOID KICKBACK** by sanding in accordance with the direction arrows. Always sand on the downward side of the disc, so that the work is held securely on the table.
11. **DISCONNECT** machine from power source when making repairs.
12. **SHUT OFF** power and do not leave until the machine has come to a complete stop and the work area is clean.
13. **MAKE** all adjustments with the power "OFF."
14. **ALWAYS** remove scrap pieces and other objects from the table, backstop or abrasive disc before turning the machine "ON."
15. **NEVER** perform layout, assembly or set-up work on the table while the sander is operating.
16. **ALWAYS** turn the machine "OFF" and disconnect the cord from the power source before installing or removing accessories.
17. **NEVER** leave the machine work area when the power is "ON" or before the machine has come to a complete stop.
18. **DO NOT** sand pieces of material that are too small to be safely supported on the table.
19. **AVOID** awkward hand positions where a sudden slip could cause a hand to move into the abrasive disc.
20. **WHEN** sanding a large workpiece, provide additional support at table height.
21. **SHOULD** any part of your sander be missing, damaged, or fail in any way, or any electrical component fail to perform properly, shut off switch and remove plug from power supply outlet. Replace missing, damaged, or failed parts before resuming operation.
22. **THE USE** of attachments and accessories not recommended by Delta may result in the risk of injuries.
23. **ADDITIONAL INFORMATION** regarding the safe and proper operation of this product is available from the National Safety Council, 1121 Spring Lake Drive, Itasca, IL 60143-3201 in the Accident Prevention Manual for Industrial Operation and also in the Safety Data Sheets provided by the NSC. Please also refer to the American National Standards Institute ANSI 01.1 Safety Requirements for Woodworking Machinery and the U.S. Department of Labor OSHA 1910.213 Regulations.
24.  **DO NOT EXPOSE** to rain or use in damp location.
25. **DO NOT** apply brake when the switch is in the "ON" position.
26. **SAVE THESE INSTRUCTIONS.** Refer to them frequently and use them to instruct other users.

## SPECIFICATIONS

**Motor:** 1/2 H.P., 120V, Single Phase

**Disc Speed:** 1725 RPM

**Disc Size:** 12"

**Table Size:** 17-1/4" x 6-1/4"

**Table Tilt:** 45° up and down

**Height:** 15"

**Width:** 17-1/4"

**Depth:** 17-3/4"

**Weight:** 72 lbs.

# UNPACKING AND CLEANING

Your new Disc Sander is shipped complete in one container. Carefully unpack the sander and all loose items from the shipping container. Fig. 2, illustrates the sander and all loose items. Remove the protective coating from machined surfaces of the machine. This coating can be removed with a soft cloth moistened with kerosene (**do not use acetone, gasoline or lacquer thinner for this purpose**). After cleaning, cover all unpainted surfaces with a good quality paste wax.

- 1 - Sander
- 2 - Hose
- 3 - 4mm Hex Wrench
- 4 - 8mm - 10mm Open-end Wrench

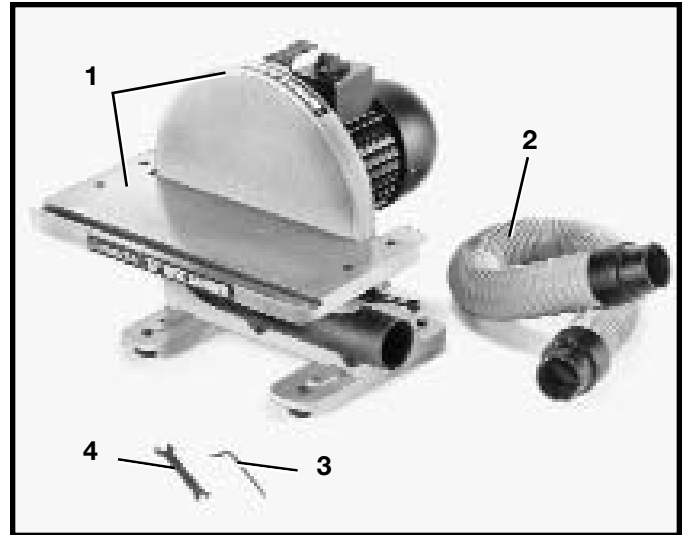

Fig. 2

## ASSEMBLY INSTRUCTIONS

The 12" Disc Sander is shipped completely assembled, except the dust hose. **⚠WARNING: FOR YOUR OWN SAFETY, DO NOT CONNECT THE SANDER TO THE POWER SOURCE UNTIL THE MACHINE IS COMPLETELY ASSEMBLED AND YOU HAVE READ AND UNDERSTOOD THE ENTIRE OWNER'S MANUAL.**

### INSTALLING DUST HOSE

The 12" Disc Sander has an efficient, integral fan which provides excellent dust collection. We suggest that a dust collector of some kind be hooked up to the machine. If dust collection is not available, insert one end of the supplied dust hose (A) Fig. 3, into the dust port (B) of the sander as shown and drape dust hose (A) down into a garbage can. Dust port (B) measures 2-1/4" I.D.

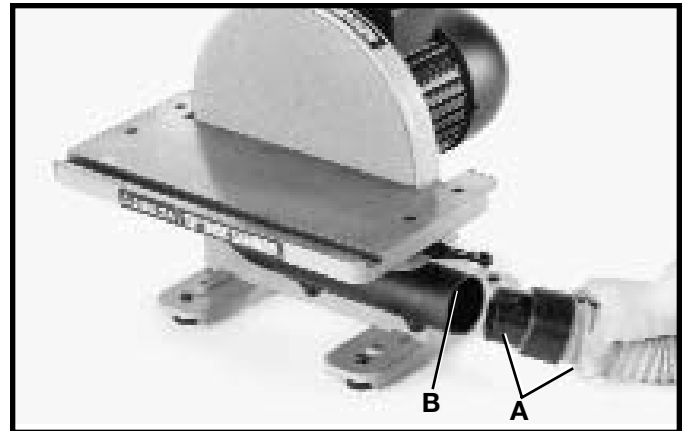

Fig. 3

### FASTENING SANDER TO SUPPORTING SURFACE

**IMPORTANT: IF DURING OPERATION THERE IS ANY TENDENCY FOR THE SANDER TO TIP OVER, SLIDE OR WALK ON THE SUPPORTING SURFACE, THE SANDER MUST BE SECURED TO THE SUPPORTING SURFACE USING FASTENERS THROUGH THE FOUR HOLES (C) FIG. 4.**

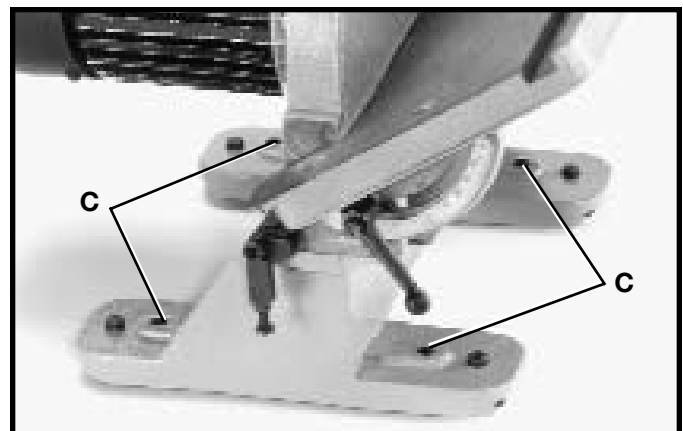

Fig. 4

# CONNECTING DISC SANDER TO POWER SOURCE

## POWER CONNECTIONS

A separate electrical circuit should be used for your tools. This circuit should not be less than #12 wire and should be protected with a 20 Amp time lag fuse. If an extension cord is used, use only 3-wire extension cords which have 3-prong grounding type plugs and 3-pole receptacles which accept the tool's plug. Before connecting the motor to the power line, make sure the switch is in the "OFF" position and be sure that the electric current is of the same characteristics as indicated on the tool. All line connections should make good contact. Running on low voltage will damage the motor.

## MOTOR SPECIFICATIONS

Your disc sander is wired for 110-120 volt, 60 HZ alternating current. Before connecting the disc sander to the power source, make sure the switch is in the "OFF" position. The motor provides a no-load speed of 1725 RPM.

## GROUNDING INSTRUCTIONS

**CAUTION: THIS TOOL MUST BE GROUNDED WHILE IN USE TO PROTECT THE OPERATOR FROM ELECTRIC SHOCK.**

In the event of a malfunction or breakdown, grounding provides a path of least resistance for electric current to reduce the risk of electric shock. This tool is equipped with an electric cord having an equipment-grounding conductor and a grounding plug. The plug must be plugged into a matching outlet that is properly installed and grounded in accordance with all local codes and ordinances.

Do not modify the plug provided - if it will not fit the outlet, have the proper outlet installed by a qualified electrician.

Improper connection of the equipment-grounding conductor can result in risk of electric shock. The conductor with insulation having an outer surface that is green with or without yellow stripes is the equipment-grounding conductor. If repair or replacement of the electric cord or plug is necessary, do not connect the equipment grounding conductor to a live terminal.

Check with a qualified electrician or service personnel if the grounding instructions are not completely understood, or if in doubt as to whether the tool is properly grounded.

Use only 3-wire extension cords that have 3-prong

grounding type plugs and 3-hole receptacles that accept the tool's plug, as shown in Fig. 5.

Repair or replace damaged or worn cord immediately.

This tool is intended for use on a normal 120-volt circuit and has a grounded plug that looks like the plug illustrated in Fig. 5.

If a properly grounded outlet is not available, a temporary adapter, shown in Fig. 6, may be used for connecting the 3-prong grounding type plug to a 2-prong receptacle. The temporary adapter should be used only until a properly grounded outlet can be installed by a qualified electrician. The green colored rigid ear, lug, or the like extending from the adapter must be connected to a permanent ground such as a properly grounded outlet box cover. Whenever the adapter is used, it must be held in place with a metal screw.

**NOTE: In Canada, the use of a temporary adapter is not permitted by the Canadian Electric Code.**

**CAUTION: IN ALL CASES, MAKE CERTAIN THE RECEPTACLE IN QUESTION IS PROPERLY GROUNDED. IF YOU ARE NOT SURE HAVE A CERTIFIED ELECTRICIAN CHECK THE RECEPTACLE.**

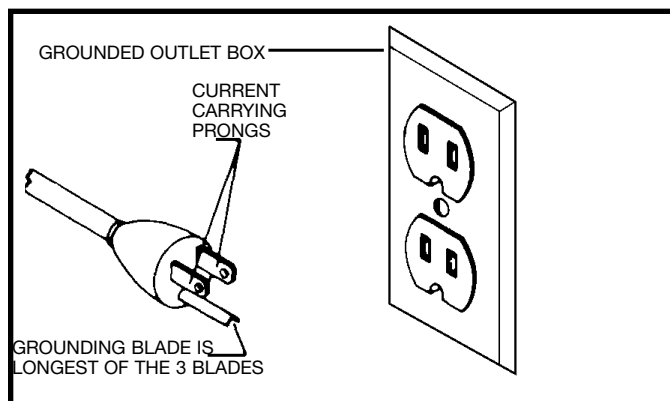

Fig. 5

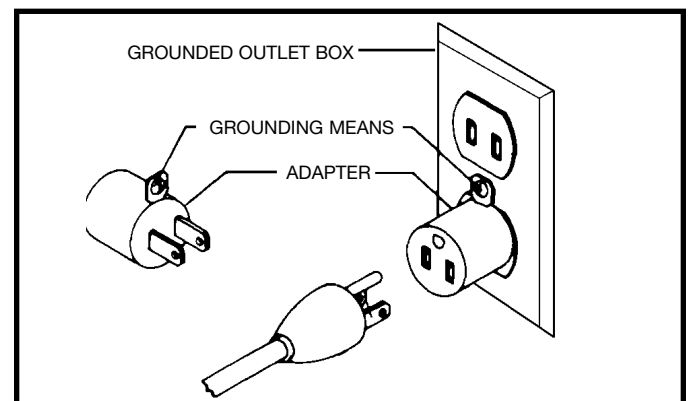

Fig. 6

# EXTENSION CORDS

Use proper extension cords. Make sure your extension cord is in good condition and is a 3-wire extension cord which has a 3-prong grounding type plug and a 3-pole receptacle which will accept the tool's plug. When using an extension cord, be sure to use one heavy enough to carry the current of the tool. An undersized cord will cause a drop in line voltage resulting in loss of power and overheating. Fig. 7, shows the correct gauge to use depending on the cord length. If in doubt, use the next heavier gauge. The smaller the gauge number, the heavier the cord.

MINIMUM GAUGE EXTENSION CORD			
RECOMMENDED SIZES FOR USE WITH STATIONARY ELECTRIC TOOLS			
Ampere Rating	Volts	Total Length of Cord in Feet	Gauge of Extension Cord
0-6	120	up to 25	18 AWG
0-6	120	25-50	16 AWG
0-6	120	50-100	16 AWG
0-6	120	100-150	14 AWG
6-10	120	up to 25	18 AWG
6-10	120	25-50	16 AWG
6-10	120	50-100	14 AWG
6-10	120	100-150	12 AWG
10-12	120	up to 25	16 AWG
10-12	120	25-50	16 AWG
10-12	120	50-100	14 AWG
10-12	120	100-150	12 AWG
12-16	120	up to 25	14 AWG
12-16	120	25-50	12 AWG
12-16	120	GREATER THAN 50 FEET NOT RECOMMENDED	

Fig. 7

## OPERATING CONTROLS AND ADJUSTMENTS

### STARTING AND STOPPING SANDER

The switch (A) Fig. 8, is located on the top of the motor. To turn sander "ON" move switch (A) toward rear of sander. To turn the sander "OFF" move switch (A) to the front position as shown.

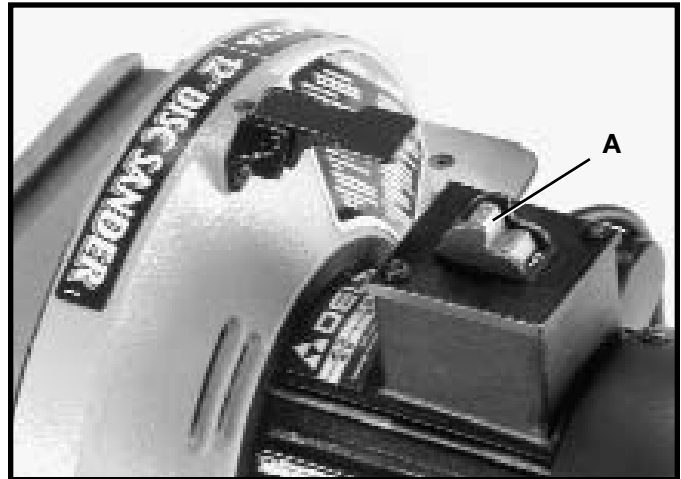

Fig. 8

### LOCKING SWITCH IN THE "OFF" POSITION

When the tool is not in use, the switch should be locked in the "OFF" position. This can be done by grasping the switch toggle (B) Fig. 9, and pulling it out of the switch, as shown. With the switch toggle (B) removed, the switch will not operate. However, should the switch toggle be removed while the machine is running, the switch can be turned "OFF" once, but cannot be restarted without inserting the switch toggle (B).

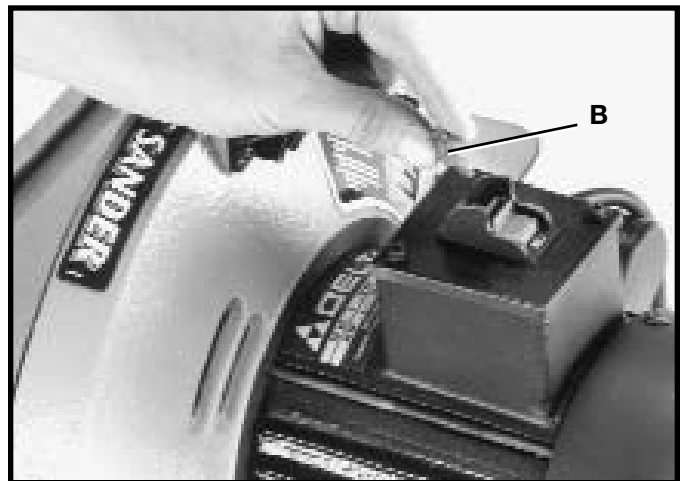

Fig. 9

# ADJUSTING MITER GAGE SLOT PARALLEL WITH THE ABRASIVE DISC

MAKE CERTAIN MACHINE IS DISCONNECTED FROM POWER SOURCE BEFORE MAKING ADJUSTMENTS.

1. Check to see if the miter gage slot (G) Fig. 10, is parallel with the disc by placing a combination square in the miter gage slot with one end of the square against the disc as shown.

2. Using a pencil, make a mark on the abrasive disc where the square contacts the disc.

3. Rotate the disc to the other end of the table and check the distance using the square. If an adjustment is necessary, proceed as follows:

4. Using the supplied wrenches (X) and (Y) Fig. 11, loosen the four screws (F) Fig. 10, which secure the table to the trunnions and adjust the table by moving it in or out until the miter gage slot is parallel with the disc. Then tighten four screws (F) Fig. 10. **NOTE:** When making this adjustment, be sure the table locking handles, one of which is shown at (A) Fig. 11, are tightened. **⚠️WARNING: TO AVOID TRAPPING THE WORK OR FINGERS BETWEEN THE TABLE AND ABRASIVE DISC, THE TABLE EDGE (Z) FIG. 10, SHOULD BE POSITIONED A MAXIMUM OF 1/16" FROM THE ABRASIVE DISC, AS SHOWN.**

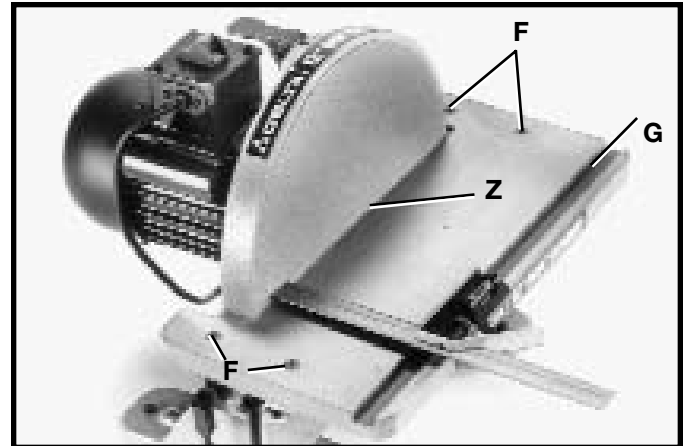

Fig. 10

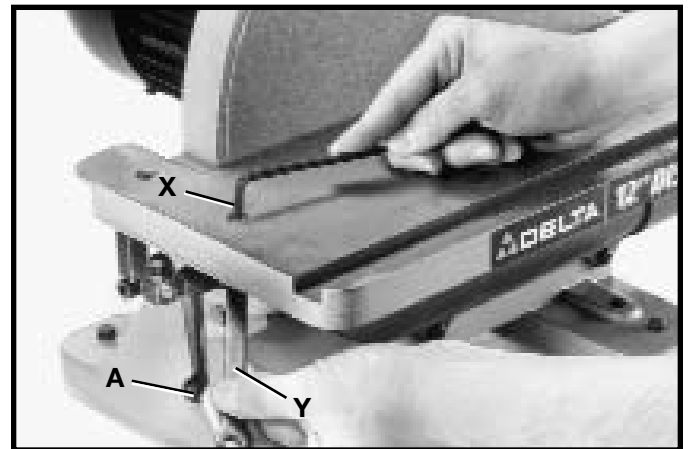

Fig. 11

## ADJUSTING TABLE SQUARE WITH ABRASIVE DISC AND ADJUSTING 90 DEGREE POSITIVE STOP

MAKE CERTAIN MACHINE IS DISCONNECTED FROM POWER SOURCE BEFORE MAKING ADJUSTMENTS.

1. Set the table to zero.

2. Place an accurate square on the table with one end of the square against the disc, as shown in Fig. 12. If the table is not square to the disc, proceed as follows: Loosen the table locking handles, one of which is shown at (A) Fig. 12, located on each end of the table. **NOTE:** Table locking handle (A) Fig. 12, is spring-loaded and can be repositioned on the stud by pulling out the handle and repositioning it on the nut.

3. Loosen locknut (B) Fig. 12, and adjust screw (C) accordingly until table is square with the abrasive disc. Then tighten table locking handles and locknut (B).

4. Loosen screw (D) Fig. 12, and adjust pointer (E) until it points to the "0" mark on the scale. Then tighten screw (D).

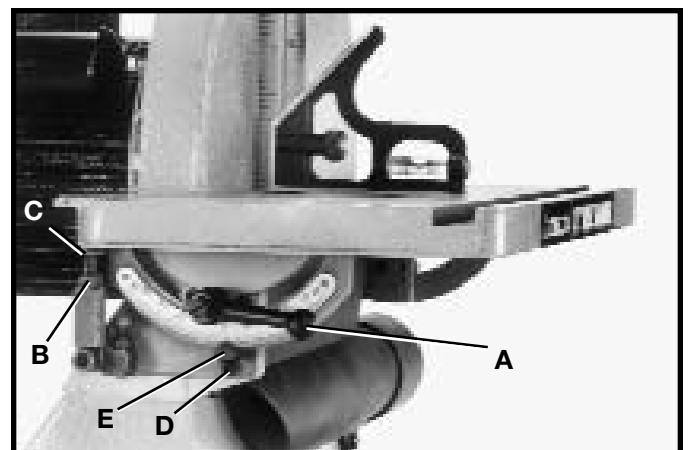

Fig. 12

# TILTING THE TABLE AND ADJUSTING THE 45 DEGREE POSITIVE STOPS

**MAKE CERTAIN MACHINE IS DISCONNECTED FROM POWER SOURCE BEFORE MAKING ADJUSTMENTS.**

The table can be tilted up to 45 degrees up or down. To tilt the table down as shown in Fig. 14, loosen table lock handles (A) Fig. 13, and pivot table until desired angle is established. Then tighten table locking handles. To tilt the table (X) up as shown in Fig. 17, loosen table lock handles (A) Fig. 13, pivot 90 degree positive stop (B) Fig. 15, to the position shown, and tilt the table to the desired angle. Then tighten table locking handles. **NOTE:** Table locking handles (A) Fig. 13, are spring-loaded and can be repositioned on the stud by pulling out the handle and repositioning it on the nut. A scale (C) Fig. 15, and pointer (D) are provided to indicate the degree of tilt.

**⚠WARNING: REGARDLESS OF WHICH POSITION THE TABLE IS TILTED, THE TABLE EDGE (Z) FIG. 14, MUST BE POSITIONED A MAXIMUM OF 1/16" FROM THE ABRASIVE DISC AS SHOWN, TO AVOID TRAPPING THE WORK OR FINGERS BETWEEN THE TABLE AND ABRASIVE DISC. FOR ADJUSTMENTS, SEE SECTION "ADJUSTING MITER GAGE SLOT PARALLEL WITH THE ABRASIVE DISC".**

**⚠WARNING: WE SUGGEST THAT ALL BEVEL SANDING APPLICATIONS BE PERFORMED WITH THE TABLE TILTED DOWN AS SHOWN IN FIG. 14; HOWEVER, IF THERE IS A NEED TO TILT THE TABLE UP AS SHOWN IN FIG. 17, THE WORKPIECE MUST BE SECURELY FASTENED OR CLAMPED TO A FIXTURE OR JIG TO PREVENT THE WORKPIECE FROM BEING TORN FROM HANDS AND BECOMING TRAPPED BETWEEN THE TABLE AND ABRASIVE DISC.**

To check and adjust the 45 degree positive stops, proceed as follows:

**MAKE CERTAIN MACHINE IS DISCONNECTED FROM POWER SOURCE BEFORE MAKING ADJUSTMENTS.**

1. Loosen table locking handles, one of which is shown at (A) Fig. 16, and tilt the table to the 45 degree down position as shown in Fig. 16, and tighten table locking handles. Place a square (E) Fig. 16, on the table and against the disc and check to see if the disc is 45 degrees to the table surface. If an adjustment is necessary, proceed as follows:

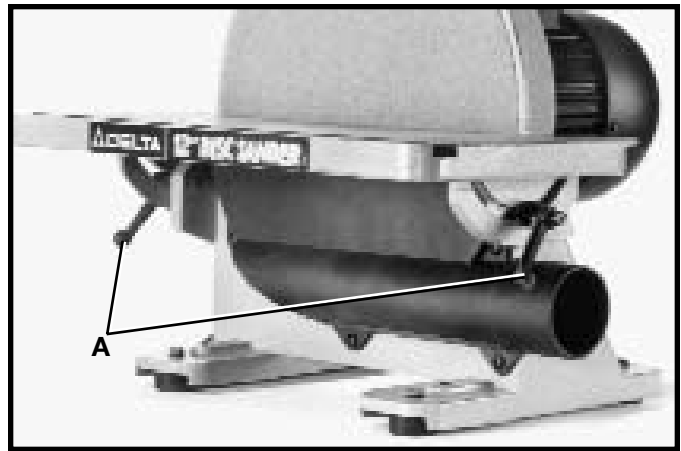

Fig. 13



Fig. 14

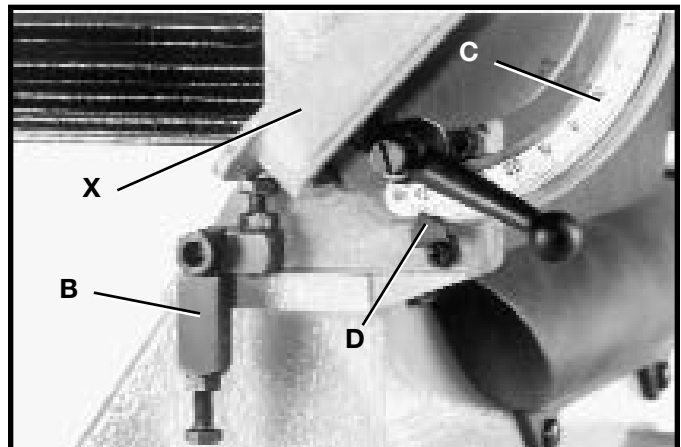

Fig. 15

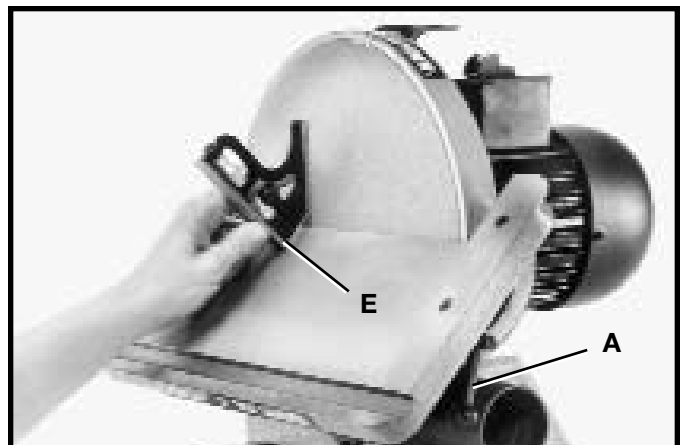

Fig. 16



2. Loosen table locking handles (A) Fig. 17, and tilt the table up as shown, to expose lock nut (F) Fig. 18, and screw (G). Loosen lock nut (F) and return table to the 45 degree down position. With the table lock handles loose, turn adjustment screw (G) using the supplied wrench (not shown) until the table is 45 degrees to the disc. Then tighten lock handles (A) Fig. 17, and locknut (F) Fig. 18.

3. Tilt the table to the 45 degree up position as shown in Fig. 17, and tighten table locking handles (A). Place a square on the table and against the disc and check to see if the disc is 45 degrees to the table surface. If an adjustment is necessary, proceed as follows:

4. Loosen table locking handles (A) Fig. 17, and locknut (H) Fig. 19, located on the left side of the table. Turn adjustment screw (J) using the supplied wrench (not shown) until the table is 45 degrees to the disc. Then tighten table locking handles and locknut (H) on adjustment screw (J).

5. Adjust pointer (K) Fig. 19, so that the pointer reads 45 degrees.

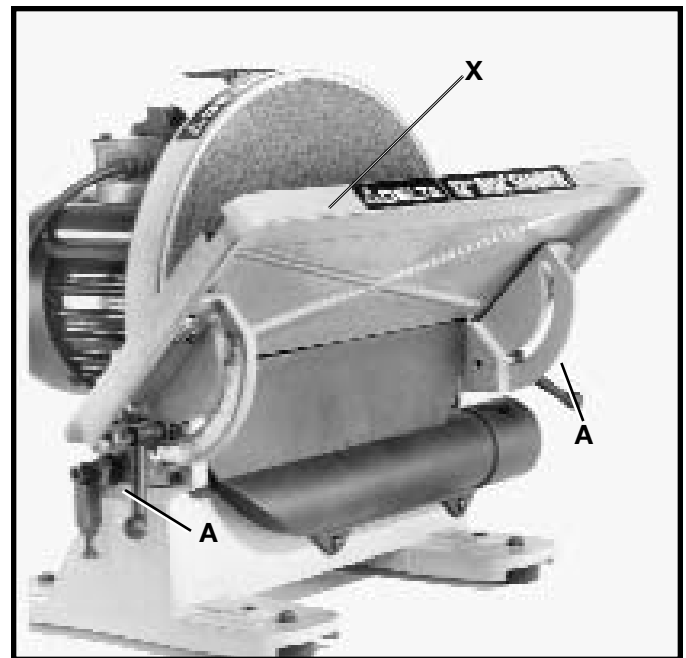

Fig. 17

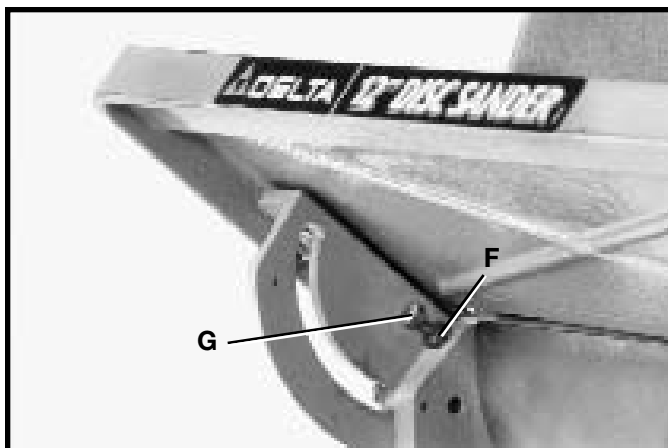

Fig. 18

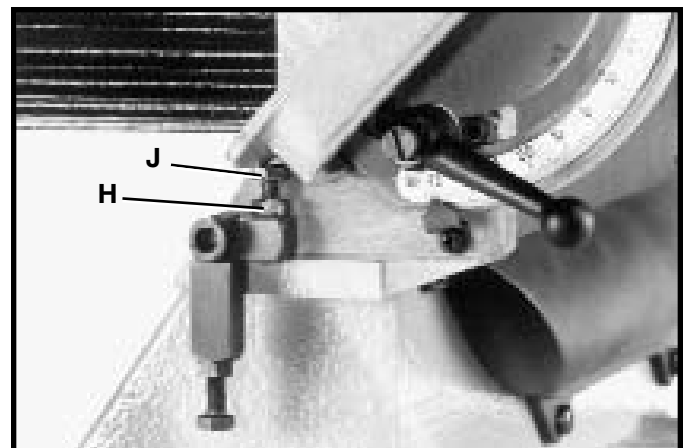

Fig. 19

## MANUAL DISC BRAKE

**⚠WARNING: APPLY THE BRAKE WHEN THE SWITCH IS IN THE "OFF" POSITION ONLY. DO NOT APPLY BRAKE WHILE SWITCH IS IN THE "ON" POSITION, FOR DAMAGE MAY OCCUR TO MACHINE.**

This 12" Disc Sander is equipped with a manual disc brake which can be applied by pressing down on brake lever (A) Fig. 20, after the switch has been turned off.

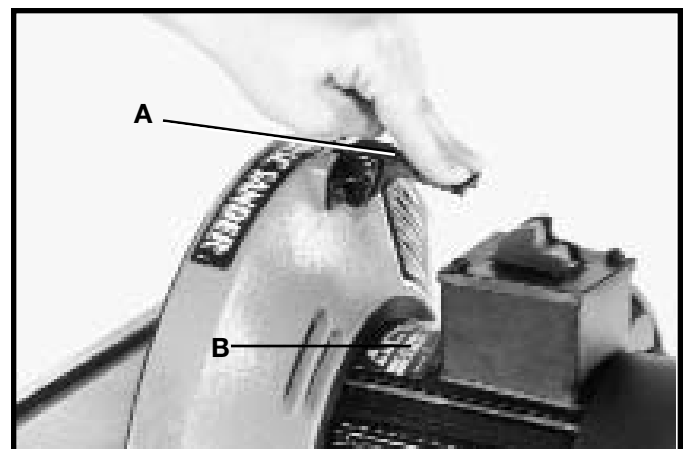

Fig. 20

# MAINTENANCE

## CHANGING ABRASIVE DISCS

**MAKE CERTAIN MACHINE IS DISCONNECTED FROM POWER SOURCE.**

1. To remove abrasive disc (A) Fig. 21, simply peel old abrasive disc from machine as shown.
2. To install a new abrasive disc, make sure the disc plate (B) Fig. 21, is clean, dry, and free from any oil or grease.
3. Remove backing from new abrasive disc.
4. Slide new abrasive disc between the table (C) Fig. 21, and disc plate (B) and press the top portion of abrasive disc (A) in position.
5. Manually rotate disc plate (B) Fig. 21, one-half turn and firmly press onto abrasive disc plate (B).

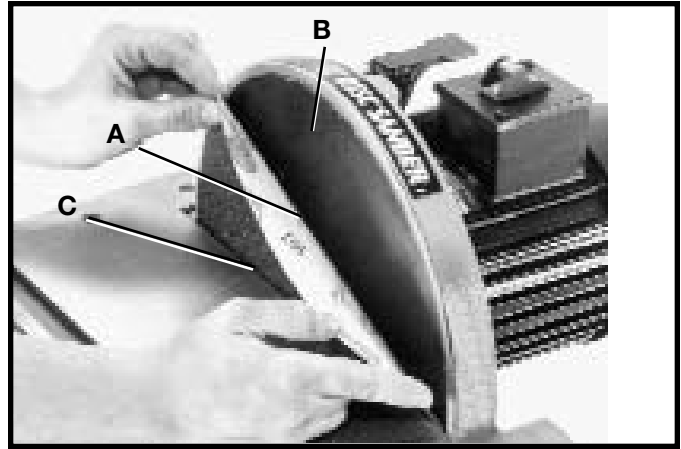

Fig. 21

6. **⚠WARNING: MAKE CERTAIN THE ABRASIVE DISC (A) FIG. 21, IS SECURELY IN POSITION BEFORE CONNECTING MACHINE TO A POWER SOURCE.**

---

## USING THE DISC SANDER

### SANDING AND END Sanding WITH ACCESSORY MITER GAUGE

The majority of work performed on the disc sander is usually accomplished using the table as a support as shown in Fig. 20, but a 3/8" x 3/4" slot (A) Fig. 22, is machined into the table of the sander to facilitate miter gauge applications as shown in Fig. 23. The use of a miter gauge will provide accurate straight and angled end-sanding as shown. Miter gauge (B) Fig. 23, is available at your nearest Delta Distributor (Cat. No. 34-779).



Fig. 22

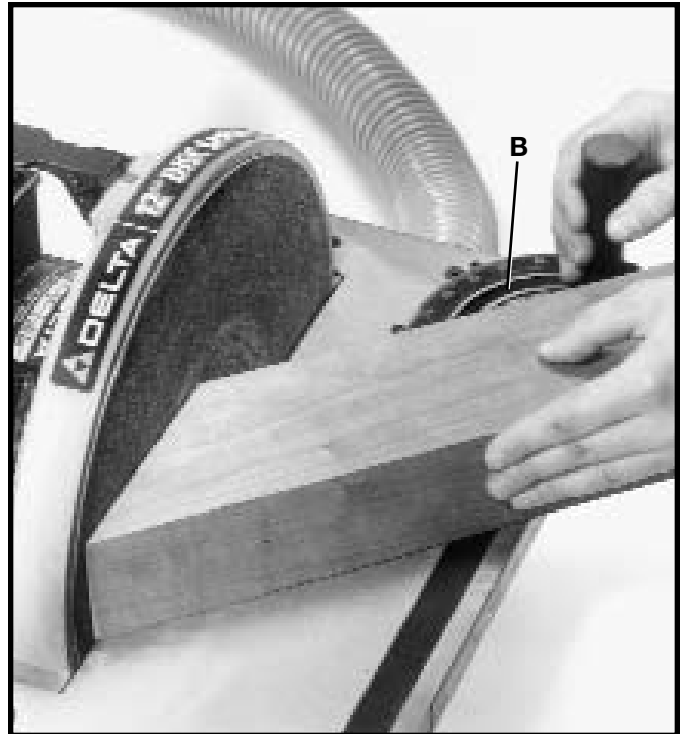

Fig. 23

# NOTES



## PARTS, SERVICE OR WARRANTY ASSISTANCE

All Delta Machines and accessories are manufactured to high quality standards and are serviced by a network of Porter-Cable•Delta Factory Service Centers and Delta Authorized Service Stations. To obtain additional information regarding your Delta quality product or to obtain parts, service, warranty assistance, or the location of the nearest service outlet, please call 1-800-223-7278, (In Canada call 1-800-463-3582).

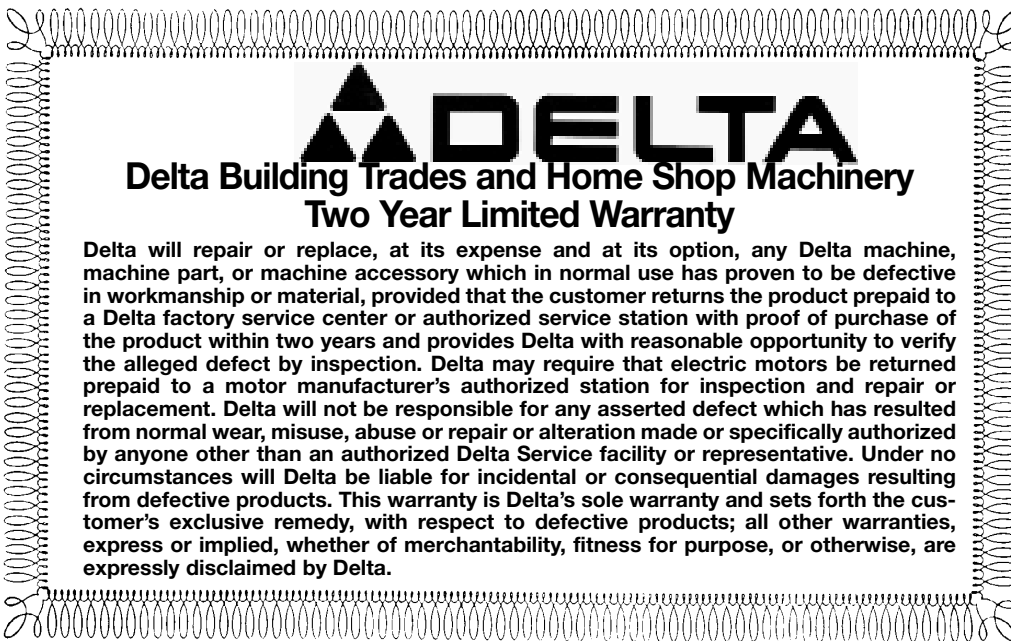

  
**Delta Building Trades and Home Shop Machinery  
Two Year Limited Warranty**

Delta will repair or replace, at its expense and at its option, any Delta machine, machine part, or machine accessory which in normal use has proven to be defective in workmanship or material, provided that the customer returns the product prepaid to a Delta factory service center or authorized service station with proof of purchase of the product within two years and provides Delta with reasonable opportunity to verify the alleged defect by inspection. Delta may require that electric motors be returned prepaid to a motor manufacturer's authorized station for inspection and repair or replacement. Delta will not be responsible for any asserted defect which has resulted from normal wear, misuse, abuse or repair or alteration made or specifically authorized by anyone other than an authorized Delta Service facility or representative. Under no circumstances will Delta be liable for incidental or consequential damages resulting from defective products. This warranty is Delta's sole warranty and sets forth the customer's exclusive remedy, with respect to defective products; all other warranties, express or implied, whether of merchantability, fitness for purpose, or otherwise, are expressly disclaimed by Delta.