



Operating Instructions — Parts Manual
15-Inch Vari-Speed Drill Press

Models: A5816, A5818, A3816, A3818

Manufactured after Serial No. 807137
5507564

Part No.
Revision B6

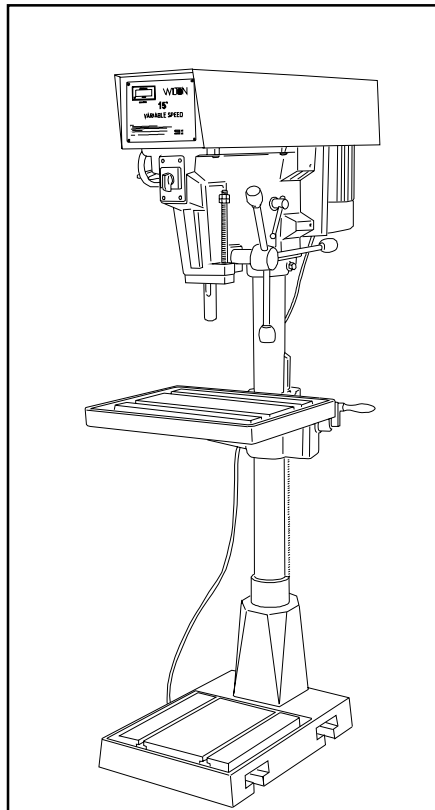

WMH Tool Group, Inc.
2420 Vantage Dr.
Elgin, IL 60123
Ph: 847-649-3010
Fax: 847-851-1144

Table of Contents

Cover Page.....	1
General Specifications	4
Operating Precautions	5
Set-up and Operation	7
Maintenance.....	9
Wiring Diagrams	10
Troubleshooting	11
Replacement Parts	12

General Specifications

The Wilton 15-Inch Vari-Speed Drill Presses, Models A5816, A5818, A5836, and A5838 provide drilling speeds from 400 to 5,000 rpm. Simple handwheel adjustment sets the speeds with an LED speed display on the faceplate of the machine.

Wilton's 15-inch vari-speed drill press provides a solid base for drilling and offers a wide range of spindle speeds. The large quill provides greater accuracy. The large worktable provides the operator with room to work and ample support for the workpiece. The drill press has a 3-inch diameter column for head and table support. The 15-Inch Vari-Speed Drill Press is equipped with a standard table raiser.

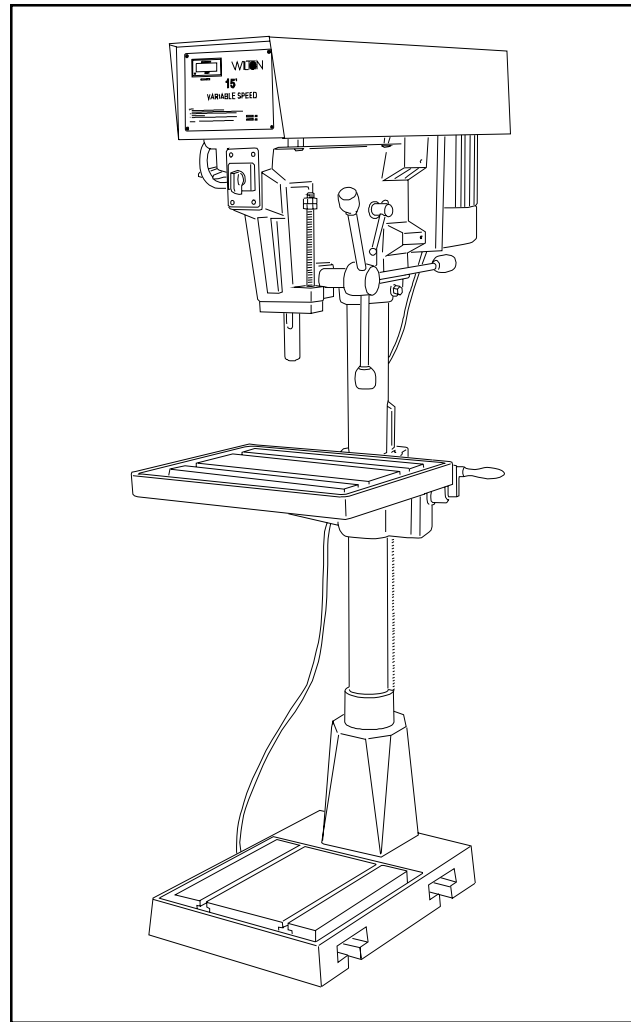

Specifications

Model	A5816	A5818	A5836	A5838
	A3816	A3818	A3836	A3838
Type	Floor Model	Floor Model	Bench Model	Bench Model
Motor:				
Motor Speed (rpm)	1,725 rpm	1,725 rpm	1,725 rpm	1,725 rpm
HP	1 HP	3 HP	1 HP	3 HP
Power Rating	1 Ph, 115/220V	3 Ph, 220/440V	1 Ph, 115/220V	3 Ph, 220/440V
Spindle speed (rpm)	400 to 5,000rpm	400 to 5,000 rpm	400 to 5,000 rpm	400 to 5,000rpm
Capacity:				
Cast iron	up to 5/8-in.	up to 5/8-in.	up to 5/8-in.	up to 5/8-in.
Steel	up to 1/2-in.	up to 1/2-in.	up to 1/2-in.	up to 1/2-in.
Drills to center	15 in.	15 in.	15 in.	15 in.
Quill diameter	2-1/4 in.	2-1/4 in.	2-1/4 in.	2-1/4 in.
Quill travel	6 in.	6 in.	6 in.	6 in.
Spindle taper	#2 MorseTaper	#2 MorseTaper	#2 MorseTaper	#2 MorseTaper
Dimensions:				
Table (overall)	15-1/4 x 17-3/4 in. ...	15-1/4 x 17-3/4 in.	15-1/4 x 17-3/4 in.	15-1/4 x 17-3/4 in.
Table (working area) ..	12-1/2 x 14-1/2 in. ...	12-1/2 x 14-1/2 in.	12-1/2 x 14-1/2 in.	12-1/2 x 14-1/2 in.
T-slot	1/2-in.	1/2-in.	1/2-in.	1/2-in.
Spindle to table	41 in.	41 in.	41 in.	41 in.
Spindle to base	47-1/2 in.	47-1/2 in.	47-1/2 in.	47-1/2 in.
Overall height	67-1/2 in.	67-1/2 in.		



WARNING

- Misuse of this machine can cause serious injury.
- For safety, machine must be set up, used and serviced properly.
- Read, understand and follow instructions in the Operating Instructions and Parts Manual which was shipped with your machine.

When setting up machine:

- Always avoid using machine in damp or poorly lighted work areas.
- Always be sure the machine support is securely anchored to the floor or the work bench.

When using machine:

- Always wear safety glasses with side shields (See ANSI Z87.1)
- Never wear loose clothing or jewelry.
- Never overreach—you may slip and fall.

When servicing machine:

- Always disconnect the machine from its electrical

supply while servicing.

- Always follow instructions in Operating Instructions and Parts Manual when changing accessory tools or parts.
- Never modify the machine without consulting Wilton Corporation.

You—the stationary power tool user—hold the key to safety.

Read and follow these simple rules for best results and full benefits from your machine. Used properly, Wilton's machinery is among the best in design and safety. However, any machine used improperly can be rendered inefficient and unsafe. It is absolutely mandatory that those who use our products be properly trained in how to use them correctly. They should read and understand the Operating Instructions and Parts Manual as well as all labels affixed to the machine. Failure in following all of these warnings can cause serious injuries.

Machinery general safety warnings

1. Always wear protective eye wear when operating machinery. Eye wear shall be impact resistant, protective safety glasses with side shields which comply with ANSI Z87.1 specifications. Use of eye wear which does not comply with ANSI Z87.1 specifications could result in severe injury from breakage of eye protection.
2. Wear proper apparel. No loose clothing or jewelry which can get caught in moving parts. Rubber soled footwear is recommended for best footing.
3. Do not overreach. Failure to maintain proper working position can cause you to fall into the machine or cause your clothing to get caught — pulling you into the machine.
4. Keep guards in place and in proper working order. Do not operate the machine with guards removed.
5. Avoid dangerous working environments. Do not use stationary machine tools in wet or damp locations. Keep work areas clean and well lit.
6. Avoid accidental starts by being sure the start switch is "OFF" before plugging in the machine.
7. Never leave the machine running while unattended. Machine shall be shut off whenever it is not in operation.
8. Disconnect electrical power before servicing. Whenever changing accessories or general maintenance is done on the machine, electrical power to the machine must be disconnected before work is done.
9. Maintain all machine tools with care. Follow all maintenance instructions for lubricating and the changing of accessories. No attempt shall be made to modify or have makeshift repairs done to the machine. This not only voids the warranty but also renders the machine unsafe.
10. Machinery must be anchored to the floor.
11. Secure work. Use clamps or a vise to hold work, when practical. It is safer than using your hands and it frees both hands to operate the machine.
12. Never brush away chips with machine in operation.
13. Keep work area clean. Cluttered areas invite accidents.
14. Remove adjusting keys and wrenches before turning machine on.
15. Use the right tool. Don't force a tool or attachment to do a job it was not designed for.
16. Use only recommended accessories and follow manufacturers instructions pertaining to them.
17. Keep hands in sight and clear of all moving parts and cutting surfaces.
18. All visitors should be kept at a safe distance from the work area. Make workshop completely safe by using padlocks, master switches, or by removing starter keys.
19. Know the tool you are using — its application, limitations, and potential hazards.

General electrical cautions

The drill press should be grounded in accordance with the National Electrical Code and local codes and ordinances. This work should be done by a qualified electrician. The drill press should be grounded to protect the user from electrical shock.

Wire sizes

Caution: for circuits which are far away from the electrical service box, the wire size must be increased in order to deliver ample voltage to the motor. To minimize power losses and to prevent motor overheating and burnout, the use of wire sizes for branch circuits or electrical extension cords according to the following table is recommended.

Conductor length	AWG (American wire gauge) number	
	240 volt lines	120 volt lines
0-50 feet	No. 14	No. 14
50-100 feet	No. 14	No. 12
Over 100 feet	No. 12	No. 8

Safety Instructions for Drill Presses

1. All work shall be secured using either clamps or a vise to the drill press table. It is unsafe to use your hands to hold any workpiece being drilled.
2. Drill press head and table shall be securely locked to the column before operating the drill press. This must always be checked prior to starting the machine.
3. Always use the correct tooling. Tooling shall always be maintained and properly sharpened. All tooling must be run at the proper speeds and feeds as they apply to the job. Use only recommended accessories and follow those manufacturers instructions pertaining to them. Tooling shall be not be forced in to any workpiece but fed according to the proper specifications. Failure to follow these instructions will not only ruin the tooling as well as the machine, but can cause serious injury.
4. Never brush away any chips while the machine is in operation. All clean up should be done when the machine is stopped.
5. Keep hands in sight. Do not put hands or fingers around, on, or below any rotating cutting tools. Leather safety gloves should be used when handling any sharp objects or cutting tools. See Figure A.
6. Always wear protective eye wear when operating, servicing or adjusting machinery. Eyewear shall be impact resistant, protective safety glasses with side shields complying with ANSI Z87.1 specifications. Use of the eye wear which does not comply with ANSI Z87.1 specifications could result in severe injury from breakage of eye protection. See Figure B.
7. When drilling in material which causes dust, a dust mask shall be worn. See Figure C.
8. Avoid contact with coolant, especially guarding the eyes.
9. Non-slip footwear and safety shoes are recommended. See Figure D.
10. Wear ear protectors (plugs or muffs) during extended periods of operation. See Figure E.

6

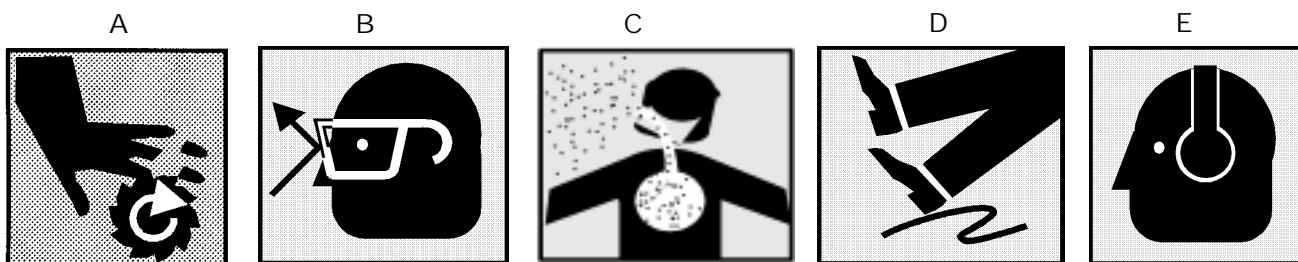

Introduction

This manual includes operating and maintenance instructions for the Wilton 15-Inch Vari-Speed Drill Presses, Models A5816, A5818, A5836, and A5838. This manual also includes parts listings and illustrations of replaceable parts.

Refer to Figure 1 for key features of the drill press.

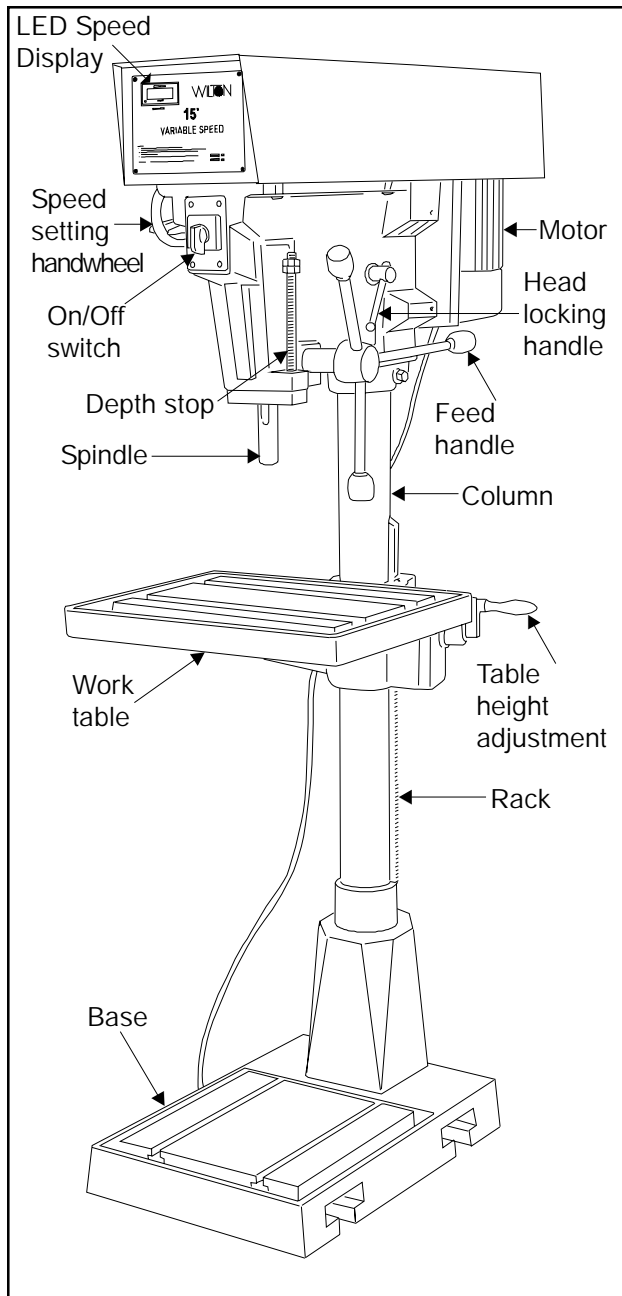

Figure 1: Drill Press Features

Set-up and Operation

Securing the Base

The base of the drill press has four mounting holes. The drill press should be level and rest solidly on the floor. Place shims under the four mounting holes in the base as required to level the drill press.

Cleaning

Clean off any protective grease with solvent. After cleaning, lubricate the base, table, and column with a light coating of medium weight machine oil. Repeat at six months intervals.

Internal parts of the drill press are lubricated at the factory. No further lubrication is required at the time of installation.

Electrical Connection

Refer to the Wiring Diagram section for wiring information. Connection to electrical power should be made by a qualified electrician. Observe local electrical codes when connecting the machine.

The motor should be protected with a time delay fuse or circuit breaker with an amperage rating slightly higher than the full load current of the motor.

Operating Controls

(Refer to Figure 2)

ON/OFF Switch

The ON/OFF switch is located at the front of the drill head.

Speed Control Handwheel

CAUTION: TO AVOID DAMAGE TO THE SPEED ADJUSTMENT MECHANISM, THE MOTOR MUST BE OPERATING BEFORE ATTEMPTING TO ADJUST THE SPEED SETTING.

The speed control handwheel is located on the left side of the drill head. An LED speed indicator is provided on the face plate on the drill head.

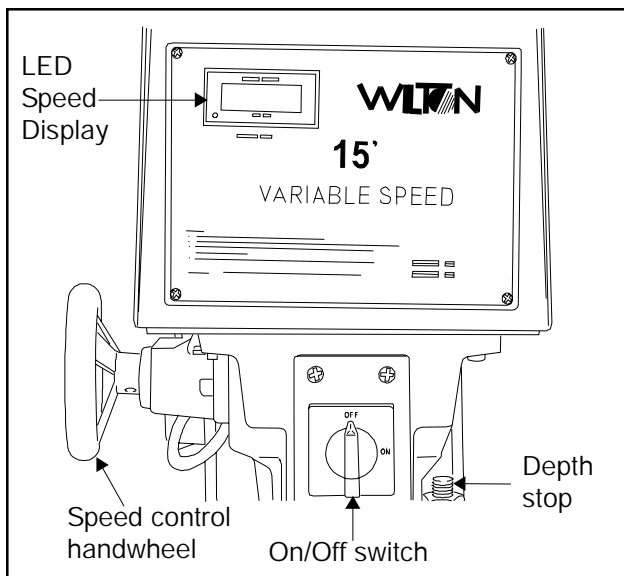

Figure 2. Operating Controls

Depth Stop

A drilling depth stop (refer to Figure 3) is provided on the right side of the drill head. The depth stop consists of a threaded rod with depth setting jam nuts. The front side of the threaded rod has a depth scale. The jam nuts are loosened and moved to the desired depth on the scale. The upper jam nut is then tightened against the lower nut.

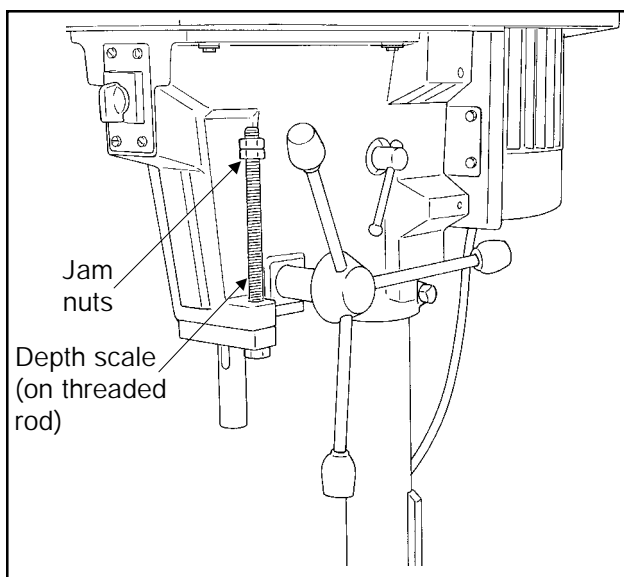

Figure 3. Depth Stop

Operating Precautions

The following operating and safety precautions must be observed in order to avoid harm to the operator or damage to the drill press.

1. The head assembly must be locked to the column so the thrust produced by drilling will not force the head assembly up the column.
2. The work table must be locked to the column so it will not be forced down the column.
3. Be sure the belt is tightened to the proper tension.
4. DO NOT start to drill the workpiece until making certain the workpiece is held down securely.
5. MAKE SURE THE DRIVE MOTOR IS RUNNING BEFORE turning the speed control handwheel in either direction.
6. Point of operation protection is required for maximum safety. This remains the responsibility of the user/purchaser since conditions differ between jobs.
7. Make sure the drill is secured in the spindle or check before attempting to use the drill press.
8. Make sure the spindle taper is clean and free of burrs, scoring, and galling to assure maximum gripping.

Drilling Recommendations

Speeds for Drilling

The speed of a drill is usually measured in terms of the rate at which the outer periphery of the tool moves in relation to the work being drilled. The common term for this is Surface Feet per Minute (SFM). The relationship of SFM is expressed in the following formulas:

$$\text{SFM} = 0.26 \times \text{rpm} \times \text{Drill Diameter (in inches)}$$

$$\text{RPM} = 3.8 \times \frac{\text{SFM}}{\text{Drill diameter (in inches)}}$$

In general, the higher the speed the shorter the drill life. Operating at the low end of the speed range for a particular material will result in longer life. The most efficient speed for operating a drill depends on many variables:

1. Composition and hardness of material.
2. Depth of the hole.
3. Efficiency of the cutting fluid.
4. Type and condition of the drilling machine.
5. Desired quality of the hole.

6. Difficulty of set-up.

Indication of Extreme Speeds and Feeds

A drill that splits up the web is evidence of too much feed or insufficient tip clearance at the center as a result of improper grinding. The rapid wearing away of the extreme outer corners of the cutting edges indicates that the speed is too high. A drill chipping or braking out at the cutting edges indicates that either the feed is too heavy or the drill has been ground with too much tip clearance.

Speeds for High Speed Steel Drills

Material	Speed In SFM
Alloy Steel — 300 to 400 Brinell	20 - 30
Stainless Steel	30 - 40
Automotive Steel Forgings	40 - 50
Tool Steel, 1.2C	50 - 60
Steel, .4C to .5C	70 - 80
Mild Machinery Steel, .2C to .3C	80 - 110
Hard Chilled Cast Iron	30 - 40
Medium Hard Cast Iron	70 - 100
Soft Cast Iron	100 - 150
Malleable Iron	80 - 90
High Nickel Steel or Monel	40 - 50
High Tensile Bronze	70 - 150
Ordinary Brass and Bronze	200 - 300
Aluminum and its Alloys	200 - 300
Magnesium and its Alloys	250 - 400
Slate, Marble, and Stone	15 - 25
Plastics and similar material (Bakelite)	100 - 150
Wood	300 - 400
Titanium Alloys	10 - 25
Titanium Alloy Sheet	50 - 60

In cases where carbon steel drills are applicable, the drill should be run at speeds of from 40 to 50 percent of those given above.

Maintenance

Replacement of Drive Belt

WARNING: MAKE SURE TO DISCONNECT ELECTRICAL POWER TO THE DRILL PRESS TO AVOID THE POSSIBILITY OF INADVERTENT OPERATION AND EXPOSURE TO POTENTIALLY LETHAL VOLTAGE LEVELS.

1. Start drill press. Set speed control to highest speed. Stop drill press.
2. Disconnect electrical power to drill press.

3. Remove head cover.
4. Remove belt. (With speed control setting at the highest speed, the belt should be loose enough to remove.)
5. Install the replacement belt. Install the head cover.
6. Connect electrical power to the drill press.
7. Operate the drill press to verify correct operation.

Replacement of Motor

WARNING: MAKE SURE TO DISCONNECT ELECTRICAL POWER TO THE DRILL PRESS TO AVOID THE POSSIBILITY OF INADVERTENT OPERATION AND EXPOSURE TO POTENTIALLY LETHAL VOLTAGE LEVELS.

1. Disconnect electrical power to drill press.
2. Remove drive belt (refer to Replacement of Drive Belt).
3. Disconnect electrical wiring from motor junction box.
4. Remove nuts and washers from bolts securing motor to drill head. Remove motor.
5. Remove pulleys and related components from motor shaft.
6. Install pulleys and related components on replacement motor shaft.
7. Install motor on mounting bolts and secure with nuts and washers.
8. Connect electrical wiring (refer to Wiring Diagram section for wiring details).
9. Install drive belt (refer to Replacement of Drive Belt).
10. Operate drill press to verify proper operation.

Lubrication

Following are lubrication recommendations for drill press components.

1. Spindle pulley drive: Lubricate spindle splines occasionally with light grease.
2. Quill, Table, and Column: Lubricate with light film of oil.
3. Table lift rack: Lubricate regularly with SAE20 oil (clean rack with solvent before applying oil.)
4. Variable speed drive fork: Lubricate contact points occasionally with grease.

Adjustments

Table Adjustment

The table can be raised or lowered to accommodate the height of the component being drilled (refer to Figure 4). To raise or lower the table, loosen the lock handle. Then use the hand crank to move the table to the desired height. Then retighten the lock handle.

Figure 4. Table Adjustment

Head Adjustment

WARNING: CHANGE THE RADIAL POSITION OF THE DRILL HEAD ONLY IF THE DRILL PRESS BASE IS SECURED TO THE FLOOR. SWINGING THE DRILL HEAD WITHOUT THE BASE BEING SECURED TO THE FLOOR WILL CAUSE THE DRILL PRESS TO BECOME UNSTABLE AND TIP OVER RESULTING IN INJURY AND/OR DAMAGE TO THE MACHINE.

The radial position of the drill head can be changed

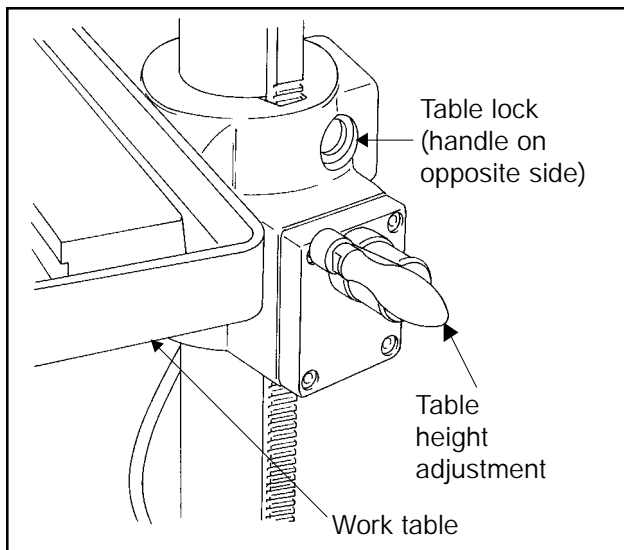

to accommodate the drilling of a hole that may be offset from the center of the table. Reposition the drill head by loosening the locking handles and swinging the drill head to the desired position. Then retighten the locking handles.

Wiring Diagrams

Refer to Figure 5 for wiring information. The drive motor is 115/230 volt single phase or 220/440 volt three phase. Notice: When converting machine voltage, it is necessary to re-wire the LED display connection accordingly. Refer to figure 5.

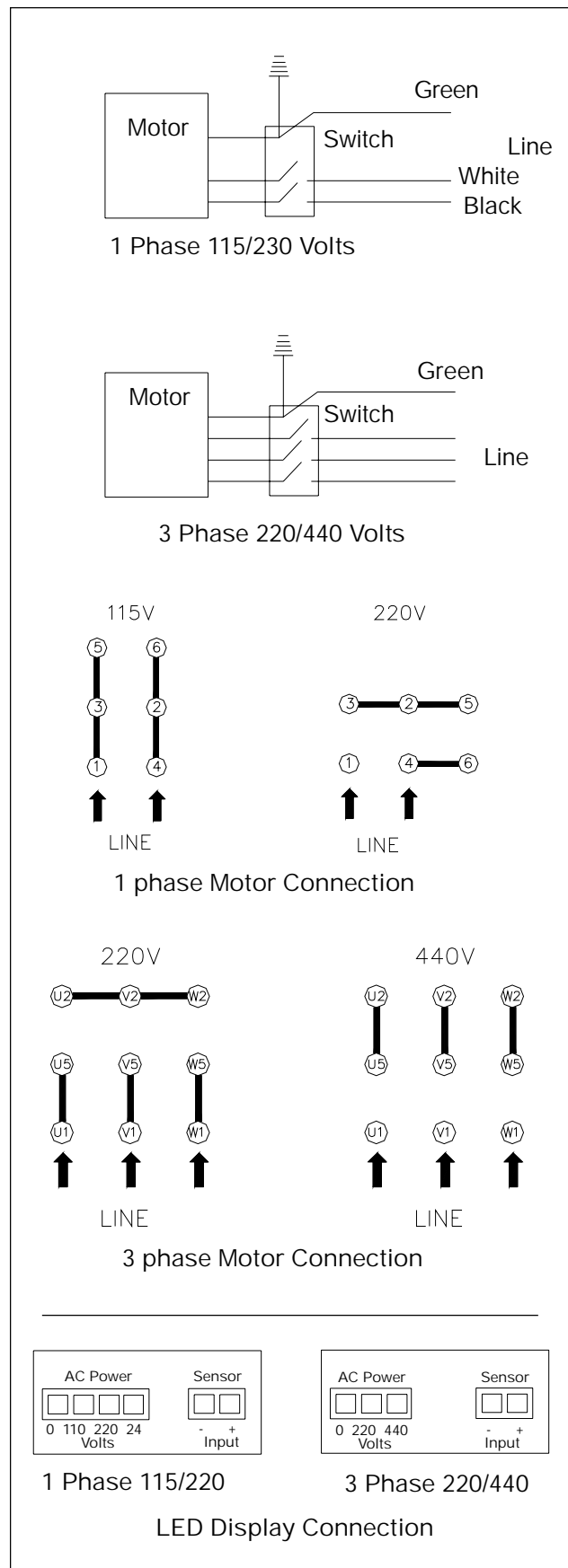

Figure 5. Wiring Diagrams

Troubleshooting

Problem	Possible Cause	Remedy
Spindle does not turn.	<ol style="list-style-type: none"> 1. Circuit breaker tripped. 2. Branch circuit breaker tripped or fuse blown. 3. Open wire in switch circuit. 4. Defective switch. 5. Broken drive belt. 	<ol style="list-style-type: none"> 1. Reset circuit breaker. 2. Reset branch circuit breaker/replace fuse. 3. Repair open circuit. 4. Repair switch. 5. Replace drive belt.
Spindle noisy.	<ol style="list-style-type: none"> 1. Damaged spindle bearings. 2. Worn spline. 	<ol style="list-style-type: none"> 1. Replace bearings. 2. Replace spline.
Drill stalls.	<ol style="list-style-type: none"> 1. Worn drive belt. 2. Excessive feed rate for size of drill and material being drilled. 3. No cutting fluid or improper cutting fluid. 	<ol style="list-style-type: none"> 1. Check condition of belt. Replace if glazed or slipping on pulleys. 2. Reduce feed pressure or use cutting fluid. 3. Use correct cutting fluid.
Poorly drilled holes.	<ol style="list-style-type: none"> 1. Drill dull. 2. Lack of rigidity in hold-down method. 3. Speed too fast for material and drill size. 4. Feed too fast for material and drill size. 5. No or improper cutting fluid or coolant being used. 6. Improperly ground drill bit. 	<ol style="list-style-type: none"> 1. Sharpen drill. 2. Check that all T-slot hold-downs are tight and that table-lock and drill head bolts are tight. 3. Check spindle speed recommendations. Reduce speed if necessary. 4. Reduce feed rate. 5. Use cutting fluid, or change to proper fluid or coolant for material being drilled. 6. Check for proper angles and reliefs. Regrind to proper geometry.
Motor overheating.	<ol style="list-style-type: none"> 1. Electrical circuit fault. 2. Oversize drill. 3. Excessive feed. 4. No cutting fluid, or wrong fluid. 	<ol style="list-style-type: none"> 1. Check current draw in circuit. Make sure current draw is the same as rating on motor plate. 2. Reduce drill size. 3. Reduce feed rate. 4. Use correct cutting fluid for the material and drill.
Table can not be raised.	<ol style="list-style-type: none"> 1. Lack of lubrication. 	<ol style="list-style-type: none"> 1. Lubricate.
No speed readout.	<ol style="list-style-type: none"> 1. Speed pickup out of adjustment or failed. 	<ol style="list-style-type: none"> 1. Adjust gap between speed pickup and post spindle pulley. If there is no readout on the speed indicator, replace the speed pickup.

Replacement Parts

This section provides exploded view illustrations that show the replacement parts for the Wilton 15-Inch Vari-Speed Drill Presses, Models A58 and A38 series. Also provided are parts listings that provide part number, description, and quantity. The item numbers shown on the illustration relate to the item number on the facing page of the parts listing.

Order replacement parts from:

Wilton Corporation
300 South Hicks Road
Palatine, IL 60067
TEL: 1-888-594-5866
FAX: 1-800-626-9676

Identify the replacement part by the part number shown in the parts listing. Be sure to include the model number and serial number of your machine when ordering replacement parts to assure that you will receive the correct part.

Exploded View — Head

Models: A5816, A5818, A5836, & A5838

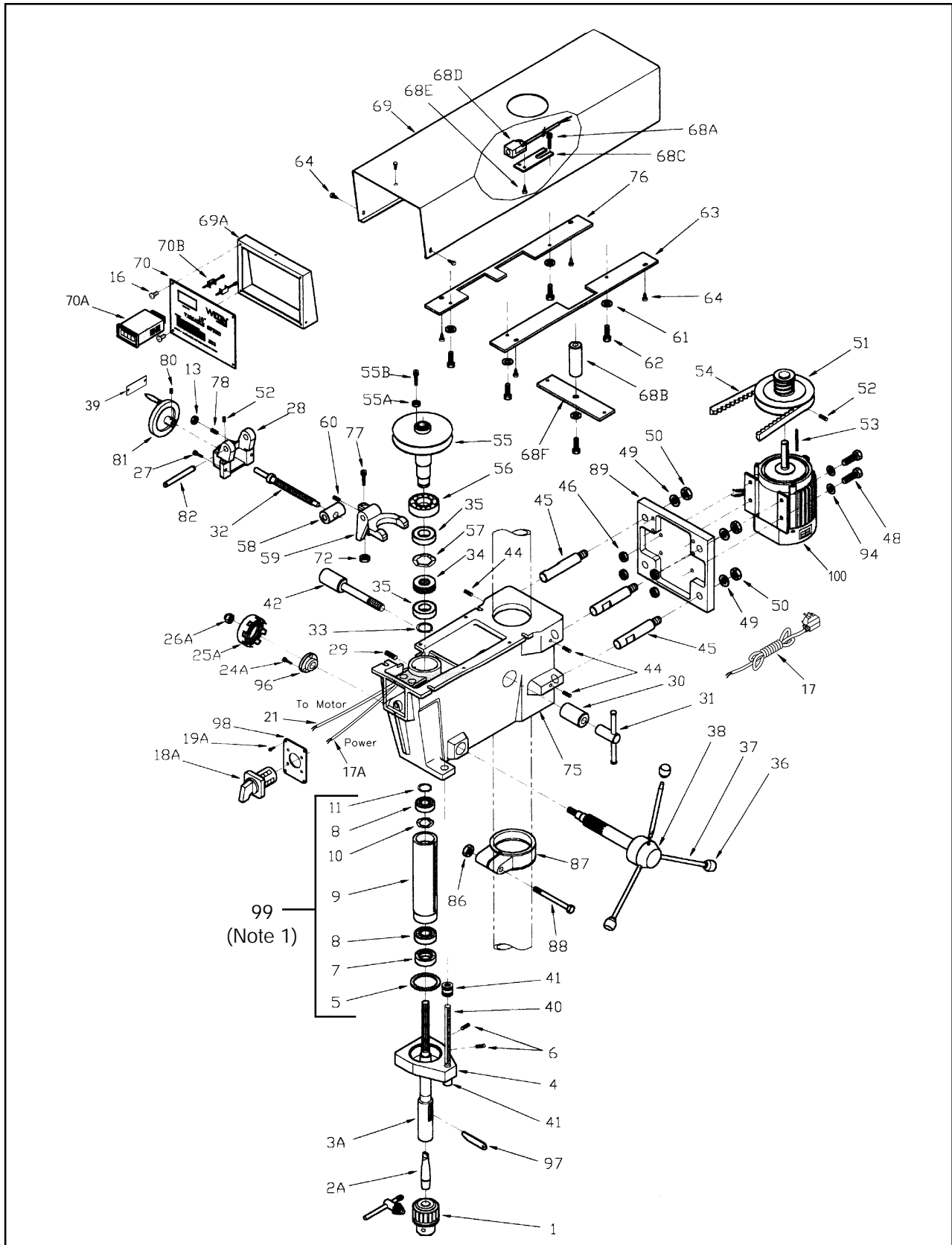

Parts List - Head

Models A5816, A5818, A5836 and A5838

Item No.	Part Number	Description	Qty	Item No.	Part Number	Description	Qty
1	5507580	Chuck (with Key)	1	53	5042011	Key (Motor)	1
2A	5507495	#2 MT x JT3 Arbor	1	54	9077101	Variable Speed Belt	1
3A	5507496	Spindle Assembly	1	55	5041140	Vaiable Speed Pulley (Spindle)	1
4	5053070	Quill Band	1	55A	5513510	Hex Nut	1
5	9010541	O-Ring	1	55B	5513511	SHCS	1
6	9054511	Set Screw 5/16-18 x 3/8	2	56	9100421	Bearing	1
7	5032611	Bearing Retainer	1	57	9058571	Spring Washer	1
8	9100331	Bearing	2	58	5041761	Speed Change Nut	1
9	5041010	Quill	1	59	5041040	Speed Change Lever	1
10	9058561	Wavy Spring Washer	1	60	9127951	Socket Set Screw 1/4-20 x 1/2	1
11	9074081	Truarc Retainer	1	61	9057461	Washer 1/4	3
13	9056981	Hex Jam Nut 1/4-20	3	62	9052101	Hex Head Cap Screw 1/4-20 x 1	4
16	5518170	Sloted self tapping Screw 3/16-24 x 3/8	5	63	5041271	Right Mounting Plate	1
17	5518157	Power Cord (1-Phase)	1	64	5518170	Self Tapping Screw 3/16-24 x 3/8	7
17A	5517463	Power Cord (3-Phase)	1	68A	TS-0208041	SHCS 5/16-18x3/4	2
18A	5507500	Switch (Single Phase)	1	68B	5513513	Spacer, Threaded	1
	5507497	Switch (3-Phase)	1	68C	5513514	Plate, Bracket	1
19A	5507501	Slotted Machine Screw 1/4-20 x 1	4	68D	5513515	Pickup, Magnetic	1
				68E	5513516	Screw	2
21	5518158	Wiring Harness (1-Phase)	1	68F	5513521	Plate	1
	5517457	Wiring Harness (3-Phase)	1	69	5041320	Cover, Pulley	1
24A	5507502	Socket Head Cap Screw	3	69A	5513517	Bracket, Face Plate	1
25A	5507503	Return Spring Assemblby	1	70	5513518	Plate, Face	1
26A	5507504	Nylon Nut	1	70A	5513519	LED Display 1Ph	1
27	9135311	Lock Screw 1/4-20 x 1	2		5513736	LED Display 3 Ph	
28	5041050	Speed Change Housing	1	70B	5513520	Screw, Locking	1
29	9127731	Socket Set Screw 5/16-18 x 5/16	1	72	9056771	Hex Jam Nut 3/8-16	1
30	5024541	Head Lock (Plain Side)	1	75	5041000	Head Casting	1
31	1000771	Lock Nut Assembly	1	76	5518172	Left Mounting Plate	1
32	5041071	Speed Change Shaft	1	77	9052831	Socket Set Screw 3/8-16 x 1	1
33	9053661	Retainer	1	78	TS-0267101	Socket Set Screw 1/4-20 x 1-1/4	1
34	5041201	Bearing Spacer	1	80	9052971	Socket Set Screw 5/16-18 x 5/16	1
35	9100321	Bearing	2	81	5034111	Hand Wheel	1
36	9070291	Knob	3	82	5513737	Shaft speed change lever	1
37	5053000	Spoke	3	86	9129051	Hex Nut 7/16-14	1
38	5507827	Feed Shaft Assembly	1	87	5041470	Collar	1
39	5513378	Hi/Lo Speed Direction Plate	1	88	9128071	Hex Head Cap Screw 7/16-14 x 3-1/2	1
40	5053100	Rod, Graduated	1	89	5032560	Motor Mounting Bracket	1
41	9056381	Jam Nut 5/8-11	3	94	TS-0680032	Washer 5/16	4
42	9128611	Hex Head Cap Screw 1/2-12 x 4	1	96	5507505	Return Spring Bracket	1
44	TS-0270031	set Screw 5/16-18 x 3/8	4	97	5507507	Drift Pin	1
45	5032781	Motor Plate Bar	4	98	5507506	Switch Mounting Plate	1
46	9057111	Whiz Flange Locknut	4	99	5507527	Quill Assembly (Note 1)	1
47	TS-0152051	Carriage Bolt 5/16-18 x 2	4	100	5507812	Motor, 1 PH 115/220 1725 RPM 60 Hz	1
48	9056171	Carriage Bolt 5/16-18 x 1-1/2	4		5514604	Motor, 1PH 115/220 1725 RPM 50 Hz	1
49	9058051	Split Lock Washer 1/2 ID	2		5507813	Motor, 3 PH 220/440 1725 RPM 50/60 Hz	1
50	9056841	Hex Nut 1/2-12	2				
51	5041170	Variable Speed Pulley (Motor)	1				
52	9054621	Socket Set Screw 1/4-20 x 1/2	2				

Note 1: Quill assembly includes items 5, 7, 8, 9,10 and 11.

Exploded View — Head

Models: A3816, A3818, A3836 & A3838

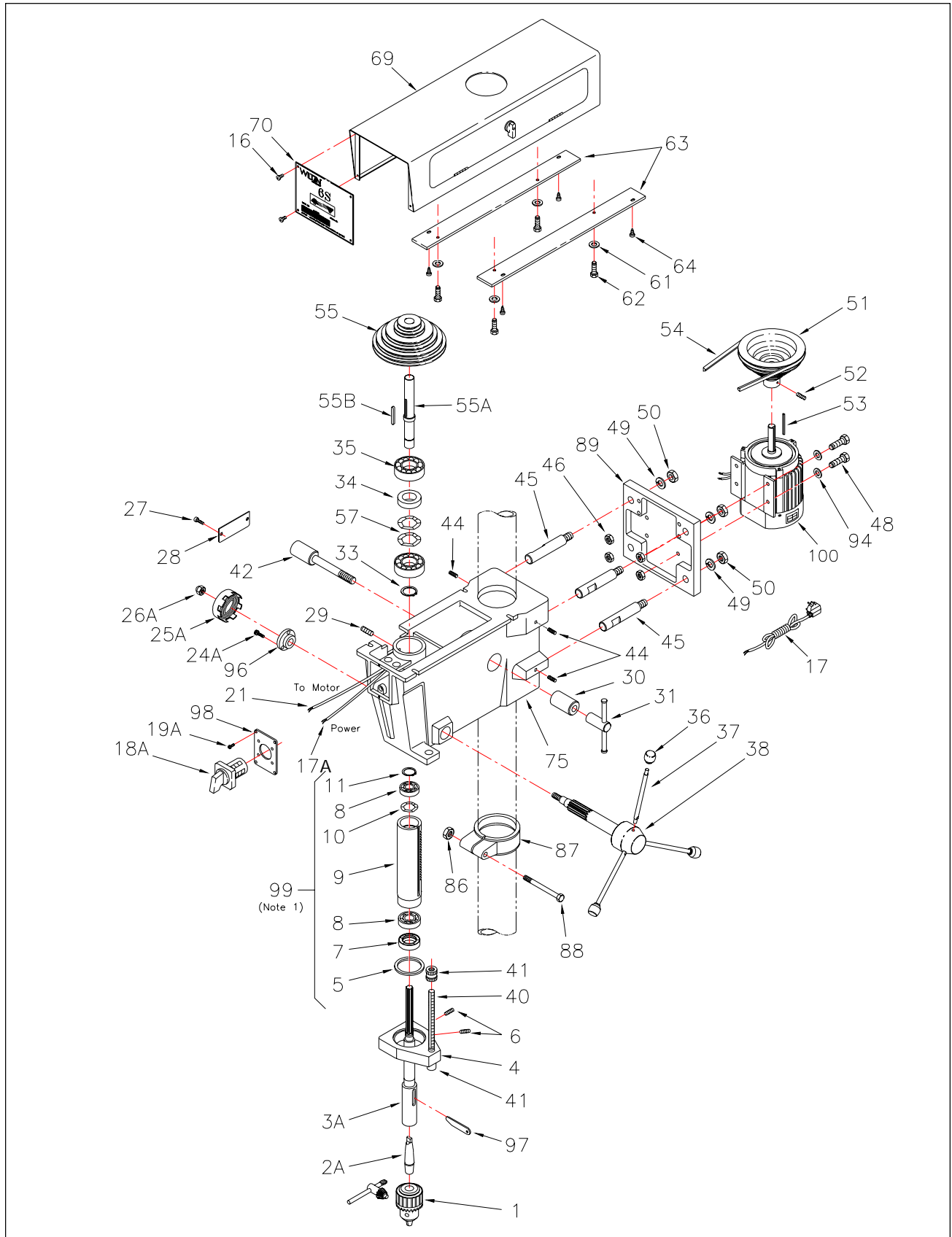

Parts List - Head

Models: A3816, A3818, A3836 & A3838

Item No.	Part Number	Description	Qty
1	5507580	Chuck (with Key)	1
2A	5507495	#2 MT x JT3 Arbor	1
3A	5507496	Spindle Assembly	1
4	5053070	Quill Band	1
5	9010541	O-Ring	1
6	9054511	Set Screw 5/16-18 x 3/8	2
7	5032611	Bearing Retainer	1
8	9100331	Bearing	2
9	5041010	Quill	1
10	9058561	Wavy Spring Washer	1
11	9074081	Truarc Retainer	1
16	9052711	Self Tapping Screw 8-32 x 3/8	4
17	5518157	Power Cord (Single Phase)	1
17A	5517463	Power Cord (3-Phase)	1
18A	5507500	Switch (Single Phase)	1
	5507497	Switch (3-Phase)	1
19A	5507501	Slotted Machine Screw	4
21	5518158	Wiring Harness (1-Phase)	1
	5517457	Wiring Harness (3-Phase)	1
24A	5507502	Socket Head Cap Screw	3
25A	5507503	Return Spring Assemblby	1
26A	5507504	Nylon Nut	1
27	5518159	Phillips Screw 1/4-20 x 5/16	2
28	5518160	Cover Plate	1
29	9127731	Socket Set Screw 5/16-18 x 5/16	1
30	5024541	Head Lock (Plain Side)	1
31	1000771	Lock Nut Assembly	1
33	9053661	Retainer	1
34	5041201	Bearing Spacer	1
35	9100321	Bearing	2
36	9070291	Knob	3
37	5053000	Spoke	3
38	5507827	Feed Shaft Assembly	1
40	5053100	Rod, Graduated	1
41	9056381	Jam Nut 5/8-11	3
42	9128611	Hex Head Cap Screw 1/2-13 x 4	1
44	9052191	Socket Set Screw 5/16-18 x 1/2	4
45	5032781	Motor Plate Bar	4
46	9057111	Whiz Flange Locknut	4
48	9056171	Carriage Bolt 5/16-18 x 1-1/2	4
49	9058051	Split Lock Washer 1/2 ID	4
50	9056841	Hex Nut 1/2-13	4
51	5518161	Step Pulley (Motor)	1
52	5518162	Socket Set Screw 1/4-20 x 5/16	2
53	5042011	Key (Motor)	1
54	5518163	Drive Belt	1
55	5518164	Step Pulley (Spindle)	1
55A	5518165	Spindle Pulley Shaft	1
55B	5518166	Key 5 x 45	1

Item No.	Part Number	Description	Qty
57	9058571	Spring Washer	2
61	9057461	Washer 1/4	3
62	9052101	Hex Head Cap Screw 1/4-20 x 1	4
63	5518167	Mounting Plate	2
64	9138011	Self Tapping Screw #10 x 3/4 Type A	4
69	5518168	Pulley Cover (w/door & latch)	1
70	5518169	Face Plate	1
75	5041000	Head Casting	1
86	9129051	Hex Nut 7/16-14	1
87	5041470	Collar	1
88	9128071	Hex Head Cap Screw 7/16-14 x 3-1/2	1
89	5032560	Motor Mounting Bracket	1
94	9055281	Rubber Washer	4
96	5507505	Return Spring Bracket	1
97	5507507	Drift Pin	1
98	5507506	Switch Mounting Plate	1
99	5507527	Quill Assembly (Note 1)	1
100	5507812	Motor, 1 PH 115/220 1725 RPM 60 Hz	1
	5514604	Motor, 1PH 115/220 1725 RPM 50 Hz	1
	5507813	Motor, 3 PH 220/440 1725 RPM 50/60 Hz	1

Note 1: Quill assembly includes items 5, 7, 8, 9, 10 and 11.

Exploded View - Base

(Floor Models A5816, A5818, A3816 & A3818)

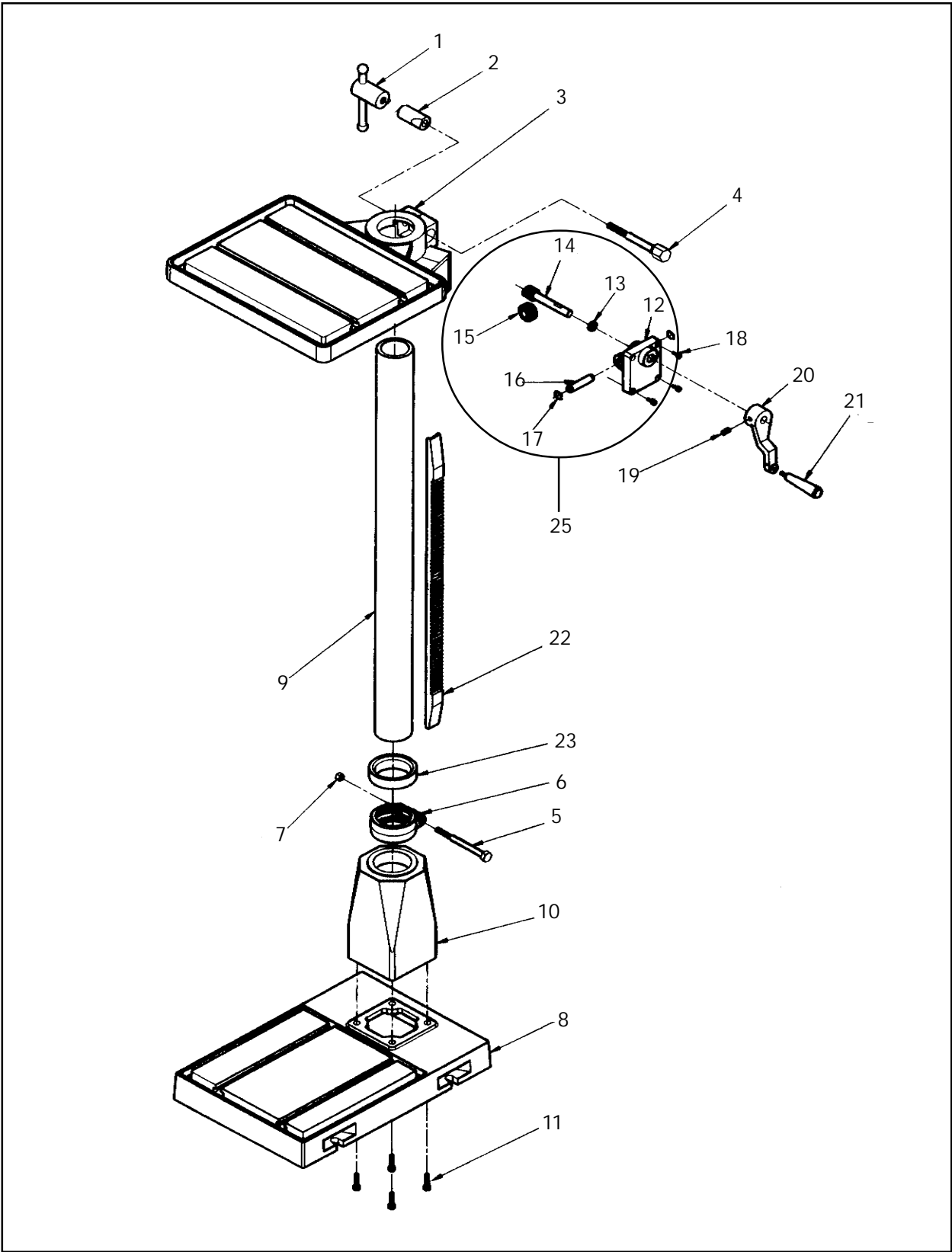

Parts List - Base

(Floor Models A5816, A5818, A3816 & A3818)

Item No.	Part Number	Description	Qty
1	1000771	Locknut	1
2	5003751	Table Lock (Plain Side)	1
3	5507508	Table	1
4	5507509	Hex Head Cap Screw	1
5	TS-0061091	Cap Screw 7/16-14 x 3-1/2	1
6	5041470	Collar	1
7	9129051	Hex Nut 7/16-14	1
8	5507528	Base	1
9	5507510	Standard Column	1
	5511850	Short Column	1
10	5507511	Flange (Base/Column)	1
11	5630771	HHCS 1/2-12 x 1-1/2	4
12	5507571	Cover Plate	1
13	5507570	Bushing	1
14	5507513	Worm, Table Raiser	1
15	5507514	Gear, Table Raiser	1
16	5507515	Shaft, Table Raiser	1
17	5507516	C-Ring, Table Raiser	2
18	TS-0050051	SHCS 1/4 x 1	4
19	5507518	Socket Head Set Screw 5/16-18 x 3/8	1
20	5507519	Crank, Table Raiser	1
21	5507520	Handle, Table Raiser	1
22	5507521	Rack	1
23	5507522	Rack Ring	1
25	5507816	Table Raiser Assembly	1

WMH Tool Group, Inc.
2420 Vantage Dr.
Elgin, IL 60123
Ph: 847-649-3010
Fax: 847-851-1144